

MODEL: PFTA 1200-4

Nozzle Loadings

Maximum Allowable Load on Boiler Steam Nozzle					
	15# Design	150# Design	200# Design	250# Design	300# Design
F_{RRF} , lb	7,470	5,220	8,965	8,965	13,705
M_{RCM} , in-lb	70,875	87,290	164,325	164,325	239,085
M_{RLM} , in-lb	120,935	71,495	139,575	139,575	186,920

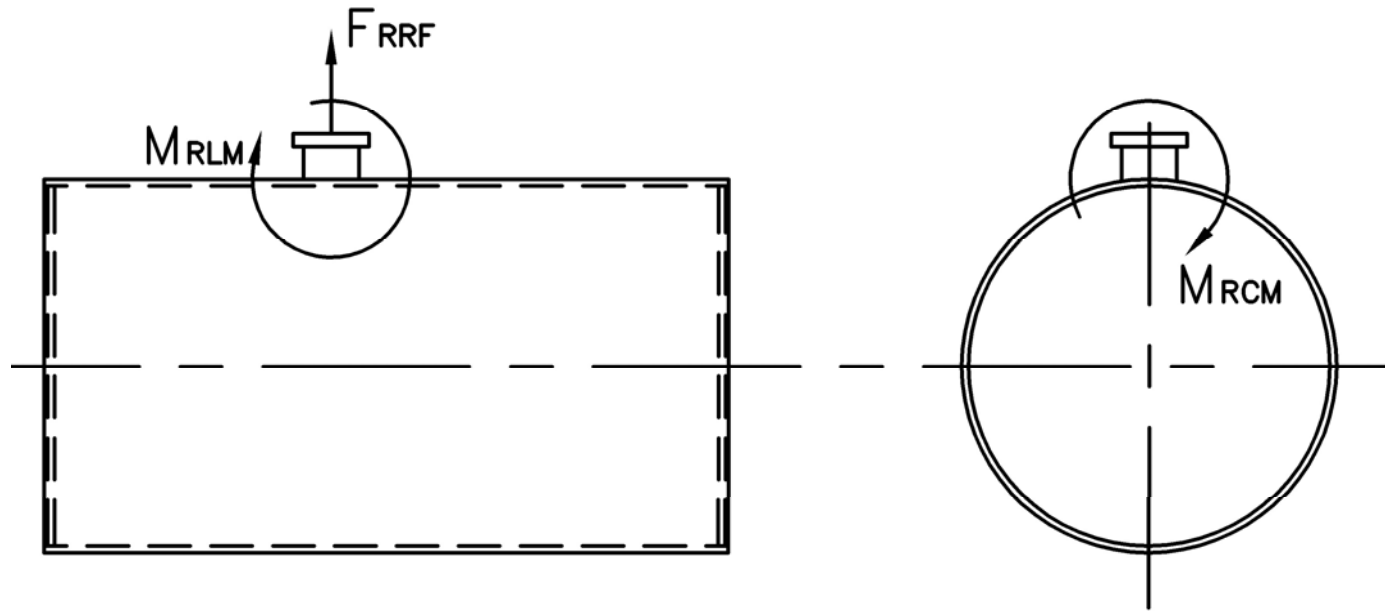

Distributed By:

Stack Emissions-Natural Gas (1,000 Btu/CF)				
	PPMv (Corr to 3% O ₂)	lb/MBtu	lb/hr @ Full Rate	Ton/Yr @ Full Rate
NO _x *	110	0.131	6.308	27.630
	30	0.036	1.720	7.535
	9	0.011	0.516	2.261
CO	50	0.037	1.77	7.751
CO ₂	2.55 lb/lb fuel	119.76	5,769	25,268
H ₂ O	2.03 lb/lb fuel	106.16	5,114	22,399
Stack Emissions-#2 Oil** (140,000 Btu/gal)				
NO _x	128	0.174	8.077	35.377
CO	50	0.037	1.704	7.465
CO ₂	3.20 lb/lb fuel	168.53	7,818	34,244
H ₂ O	1.12 lb/lb fuel	71.20	3,303	14,467

* 110 ppm "A" Burner, 30 ppm A-FGR Burner, 9 ppm FIR Burner
**0.02% fuel bound Nitrogen



MODEL: PFTA 1200-4

4-Pass Steam Packaged Firetube Boiler

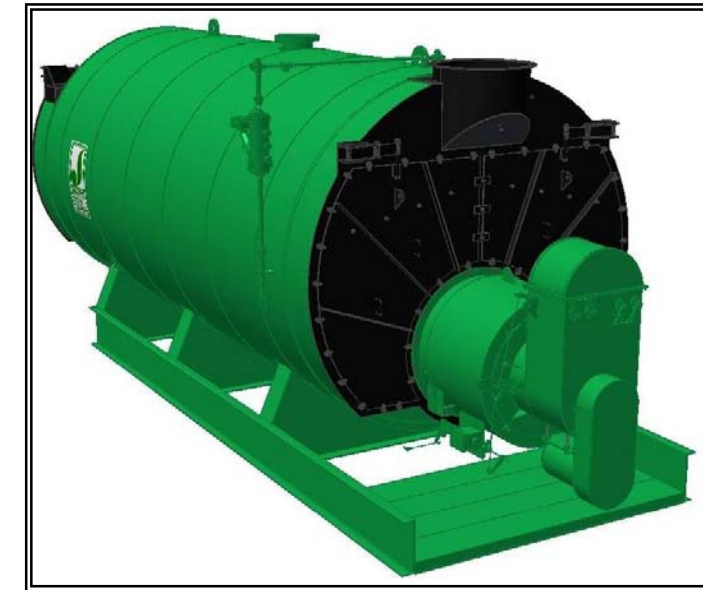

Ratings & Performance Data

Horsepower 1200							
Steam Storage, ft ³	278.3	Natural Gas Flow, SCFH (1,000 Btu/ft ³)**	48,171				
Steam Disengaging Area, ft ²	183.4	Combustion Air (15% Excess), SCFM***	8,815				
Total Heating Surface, ft ²	6,071	Flue Gas Flow Rate, lb/hr***	42,008				
Furnace Outside Diameter, in	56.0	Stack Flue Gas Velocity, ft/min***	2,110				
Furnace Heat Release Rate, Btu/ft ³ hr**	159,000	#2 Oil Flow, gal/hr (140,000 BTU/gal)**	331.4				
Total Combustion Volume, ft ³	394.5	#6 Oil Flow, gal/hr (150,000 BTU/gal)**	306.9				
Total Heat Release Rate, Btu/ft ³ hr**	122,000	Flue Gas Side Pressure Drop, in. H ₂ O	9.6				
Water Content N.W.L., gal	6,249	Water Content Flooded, gal.	8,331				
Approx. Dry Weight 15#, lb	76,700	Approx. Operating Weight 15#, lb.	129,800				
Approx. Dry Weight 150#, lb	83,200	Approx. Operating Weight 150#, lb.	136,300				
Approx. Dry Weight 200#, lb	93,100	Approx. Operating Weight 200#, lb.	146,200				
Approx. Dry Weight 250#, lb	104,300	Approx. Operating Weight 250#, lb.	157,400				
Approx. Dry Weight 300#, lb	115,600	Approx. Operating Weight 300#, lb.	168,700				
Performance Data							
Operating Pressure (psig)	Steam Rate (lb/hr)	Natural Gas		#2 Oil		#6 Oil	
		Stack Temp (F)	%Eff	Stack Temp (F)	%Eff	Stack Temp (F)	%Eff
10	41,674	264	85.8	270	89.0	278	89.7
50	40,866	322	84.4	328	87.6	337	88.3
100	40,429	362	83.4	369	86.6	378	87.3
150	40,185	391	82.7	397	85.9	407	86.6
200	40,033	413	82.2	419	85.3	430	86.0
250	39,936	431	81.7	438	84.9	448	85.5
300	39,874	447	81.3	454	84.5	465	85.1

*Based on 228°F feedwater and 3% O₂, ** Values calculated at 100 psi operating pressure, ***Calculated Firing Natural Gas



300 Pine Street
P.O. Box 300
Ferrysburg, MI 49409-0300
Telephone: (616) 842-5050
Net: www.johnstonboiler.com

Connection & Opening Schedule			
Conn.	Description	Type	Qty
FW	Feedwater Inlet	2.00 FNPT	2
MS*	Main Steam	12.00 300# RF	1
CB	Continuous Blowoff	1.00 FNPT	1
BD	Blowdown Outlet	2.00 FNPT	2
MW	Manway	12 X 16	1
HH	Hand Hole	4 X 6	7

*16.00 150#RF Flange on 15 psig Design

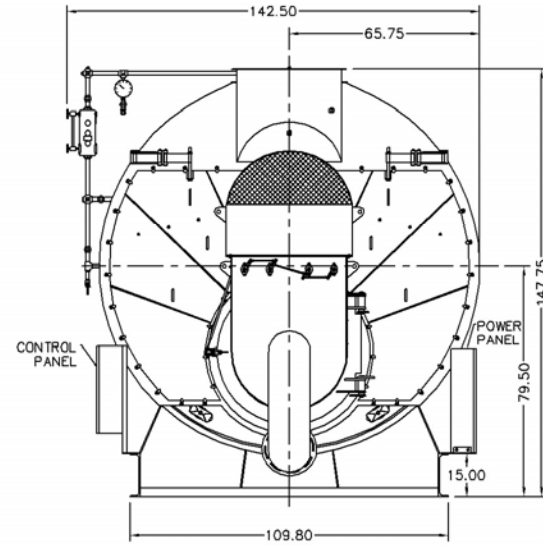

Base Diagram

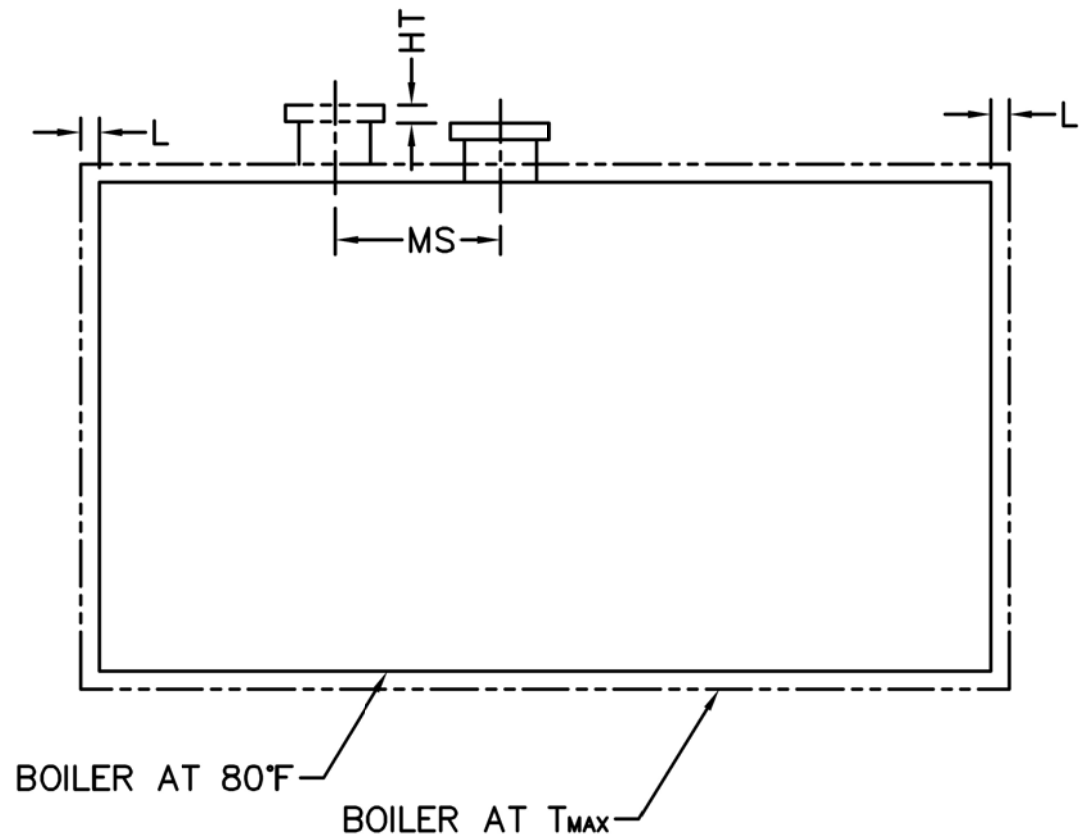
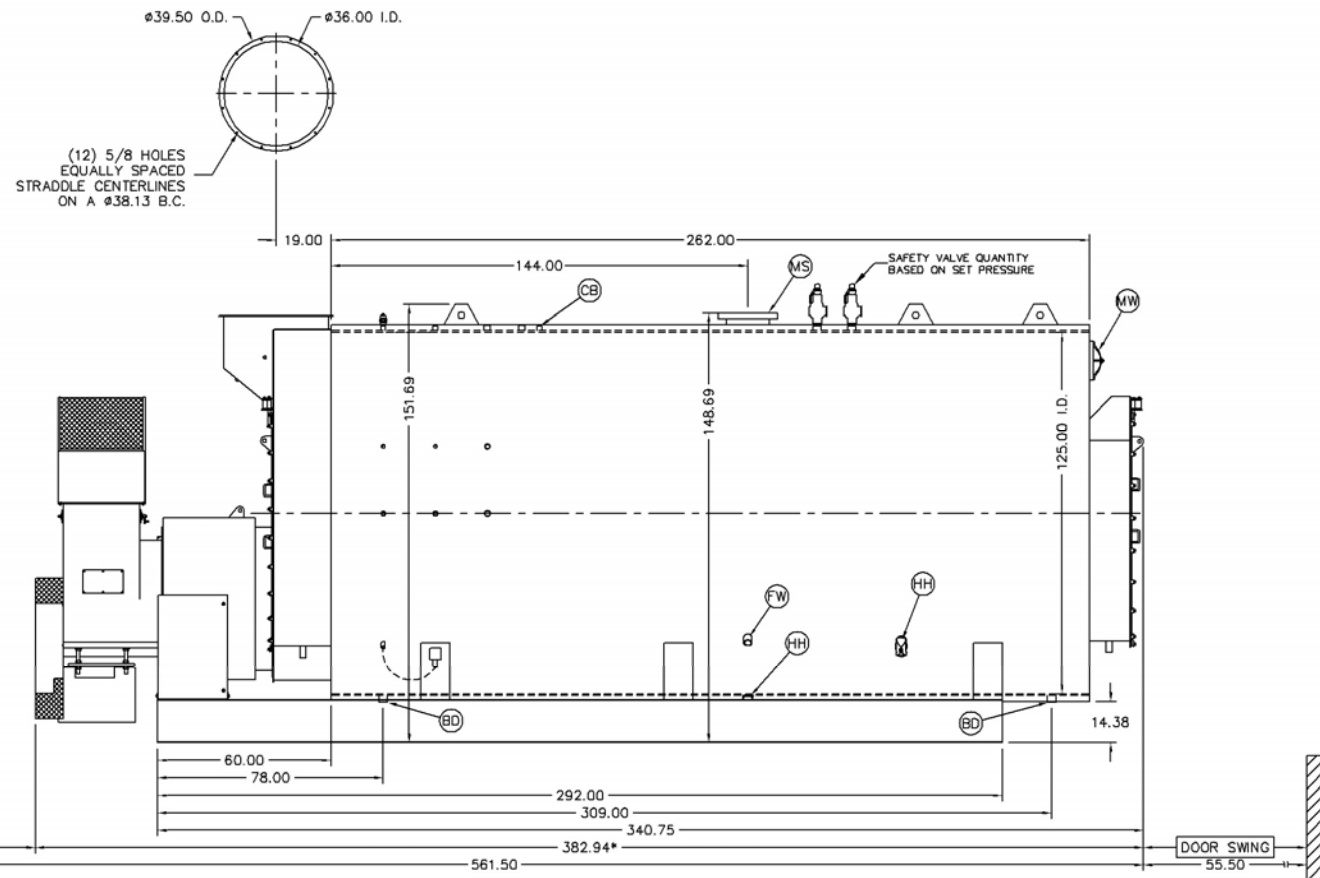
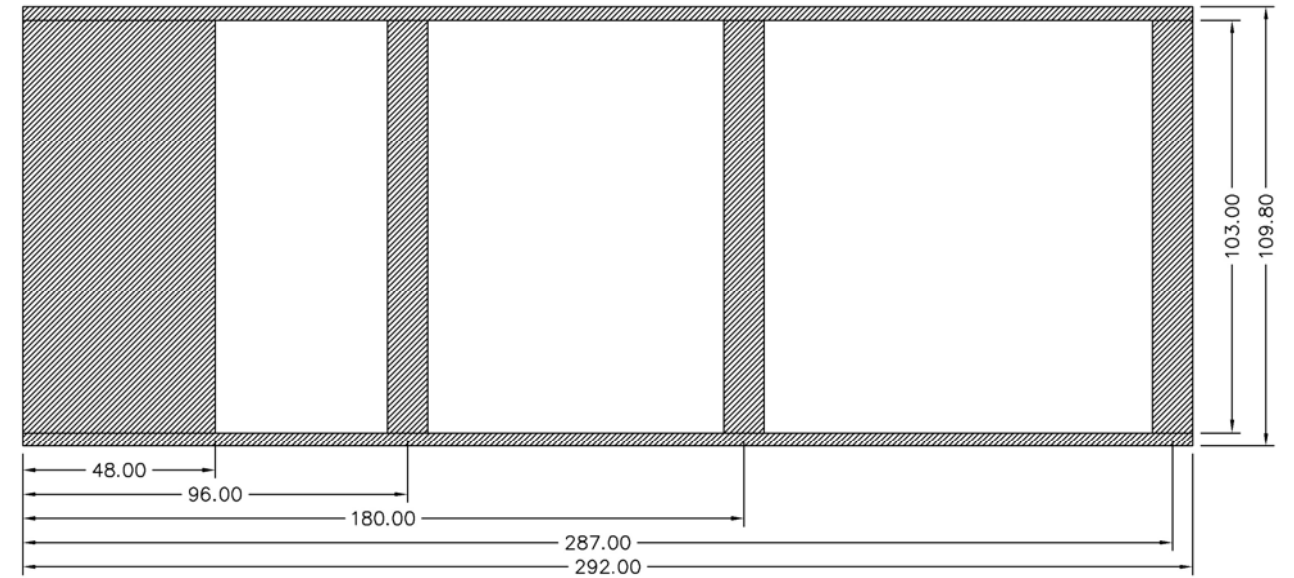

Notes:
 150# Steam design shown, all dimensions given in inches.
 Fuel piping and/or optional boiler trim may increase overall width.
 Specifications subject to change to incorporate engineering advances.
 *May vary on low-NO_x designs

Thermal Expansion					
psig	15	150	200	250	300
Metal T _{MAX} (F)	240	366	388	406	421
L (in)	0.133	0.225	0.242	0.256	0.269
MS (in)	0.013	0.022	0.024	0.025	0.027
HT (in)	0.128	0.215	0.232	0.246	0.259