

MODEL: PFTA 500-4

Nozzle Loadings

Maximum Allowable Load on Outlet & Return Nozzles				
	30# Design	60# Design	125# Design	160# Design
F _{RRF} , lb	5,210	4,245	4,935	7,605
M _{RCM} , in-lb	36,000	36,000	69,860	94,410
M _{RLM} , in-lb	56,925	46,350	57,485	76,655

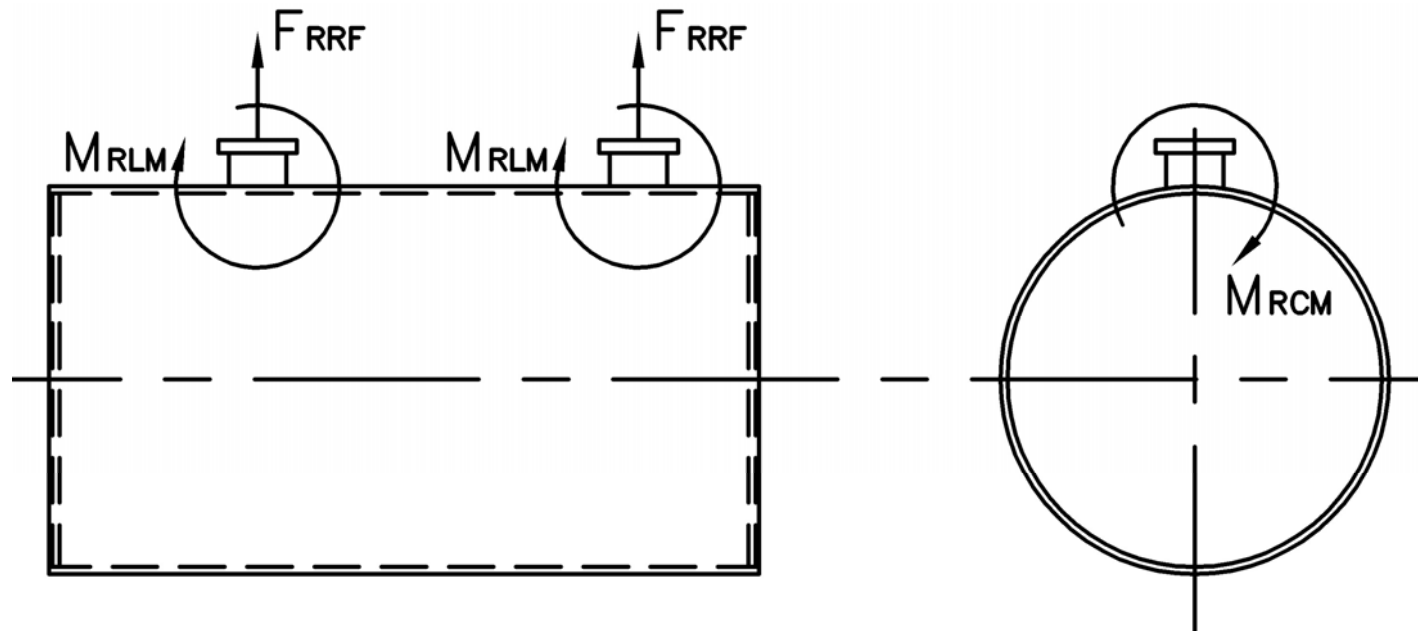

Stack Emissions-Natural Gas (1,000 Btu/CF)				
	PPMv (Corr to 3% O ₂)	lb/MBtu	lb/hr @ Full Rate	Ton/Yr @ Full Rate
NO _x *	110	0.131	2.538	11.115
	30	0.036	0.692	3.031
	9	0.011	0.208	0.909
CO	50	0.037	0.71	3.118
CO ₂	2.55 lb/lb fuel	119.76	2,321	10,165
H ₂ O	2.03 lb/lb fuel	106.16	2,057	9,011
Stack Emissions-#2 Oil** (140,000 Btu/gal)				
NO _x	128	0.174	3.255	14.255
CO	50	0.037	0.687	3.008
CO ₂	3.20 lb/lb fuel	168.53	3,150	13,798
H ₂ O	1.12 lb/lb fuel	71.20	1,331	5,829

* 110 ppm "A" Burner, 30 ppm A-FGR Burner, 9 ppm FIR Burner
**0.02% fuel bound Nitrogen

Distributed By:



300 Pine Street
P.O. Box 300
Ferrysburg, MI 49409-0300
Telephone: (616) 842-5050
Net: www.johnstonboiler.com

MODEL: PFTA 500-4

4-Pass Hot Water Packaged Firetube Boiler

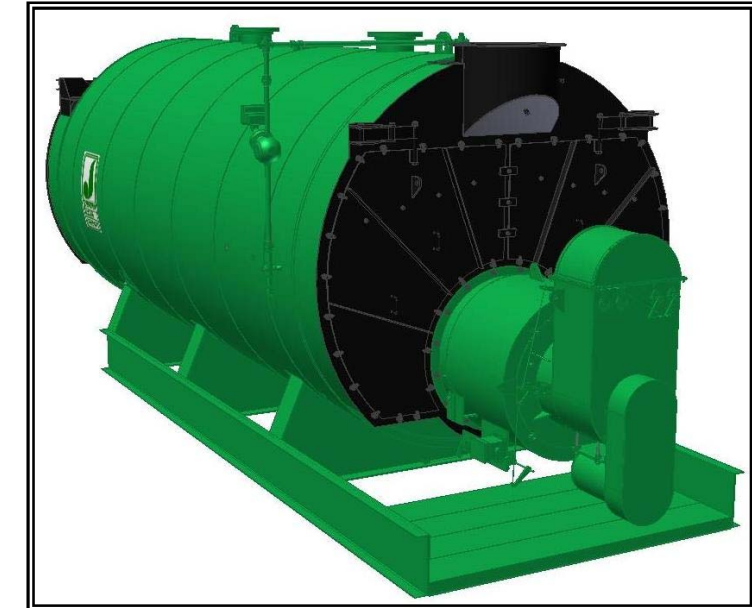

Ratings & Performance Data

Horsepower 500		Natural Gas Flow, SCFH (1,000 Btu/ft ³)**	19,379
Total Heating Surface, ft ²	2,556	Combustion Air (15% Excess), SCFM***	3,546
Furnace Outside Diameter, in	42.0	Flue Gas Flow Rate, lb/hr***	16,899
Furnace Heat Release Rate, Btu/ft ³ hr**	149,000	Stack Flue Gas Velocity, ft/min***	1,624
Total Combustion Volume, ft ³	179.8	#2 Oil Flow, gal/hr (140,000 Btu/gal)**	133.5
Total Heat Release Rate, Btu/ft ³ hr**	108,000	#6 Oil Flow, gal/hr (150,000 Btu/gal)**	123.7
Water Content Flooded, gal	3,895	Flue Gas Side Pressure Drop, in. H ₂ O	6.1
Approx. Dry Weight 30#, lb	38,200	Approx. Operating Weight 30#, lb	70,300
Approx. Dry Weight 60#, lb	38,400	Approx. Operating Weight 60#, lb	70,500
Approx. Dry Weight 125#, lb	40,100	Approx. Operating Weight 125#, lb	72,200

Performance Data						
Operating Temperature (F)	Natural Gas		#2 Oil		#6 Oil	
	Stack Temp (F)	%Eff	Stack Temp	%Eff	Stack Temp (F)	%Eff
180	219	86.9	228	90.0	237	90.7
200	239	86.4	247	89.5	257	90.2
220	259	85.9	267	89.0	277	89.7
240	279	85.4	287	88.5	297	89.2

*Based on 20°F difference in supply/return, ** Values calculated at 200°F operating temperature, ***Calculated Firing Natural Gas

Connection & Opening Schedule			
Conn.	Description	Type	Qty
FW	Feedwater Inlet	2.00 FNPT	2
WS	Water Supply	10.00 150#RF	1
WR	Water Return	10.00 150#RF	1
DO	Drain Outlet	2.00 FNPT	2
MW	Manway	12 X 16	1
HH	Hand Hole	4 X 6	7

Supply and return outlets ASME flanged drilling

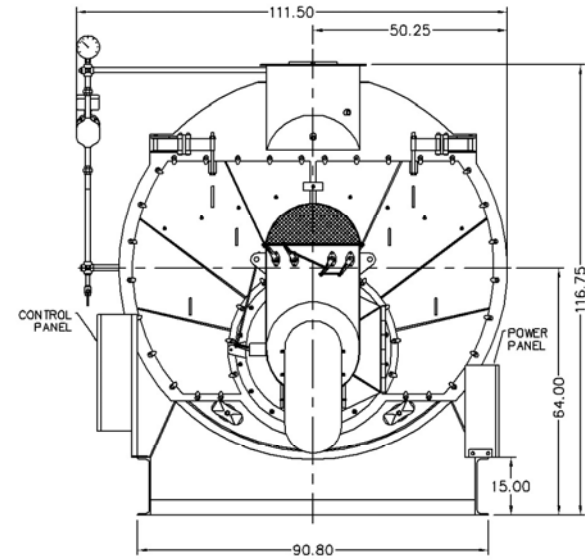

Base Diagram

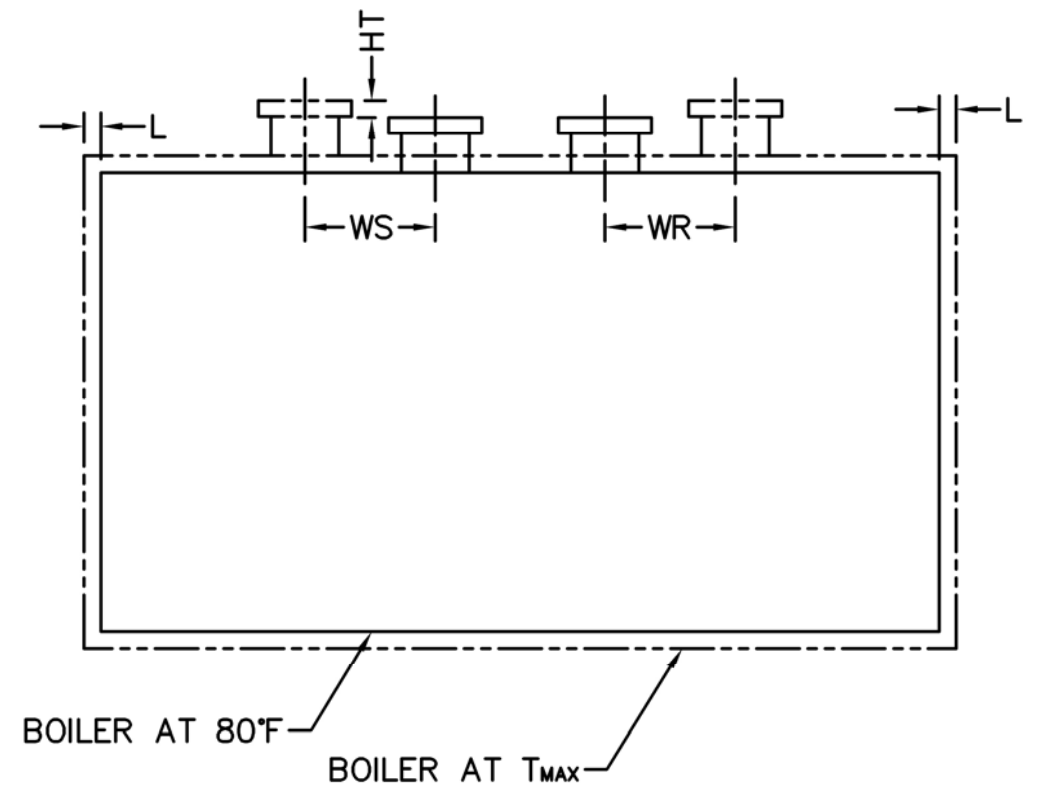
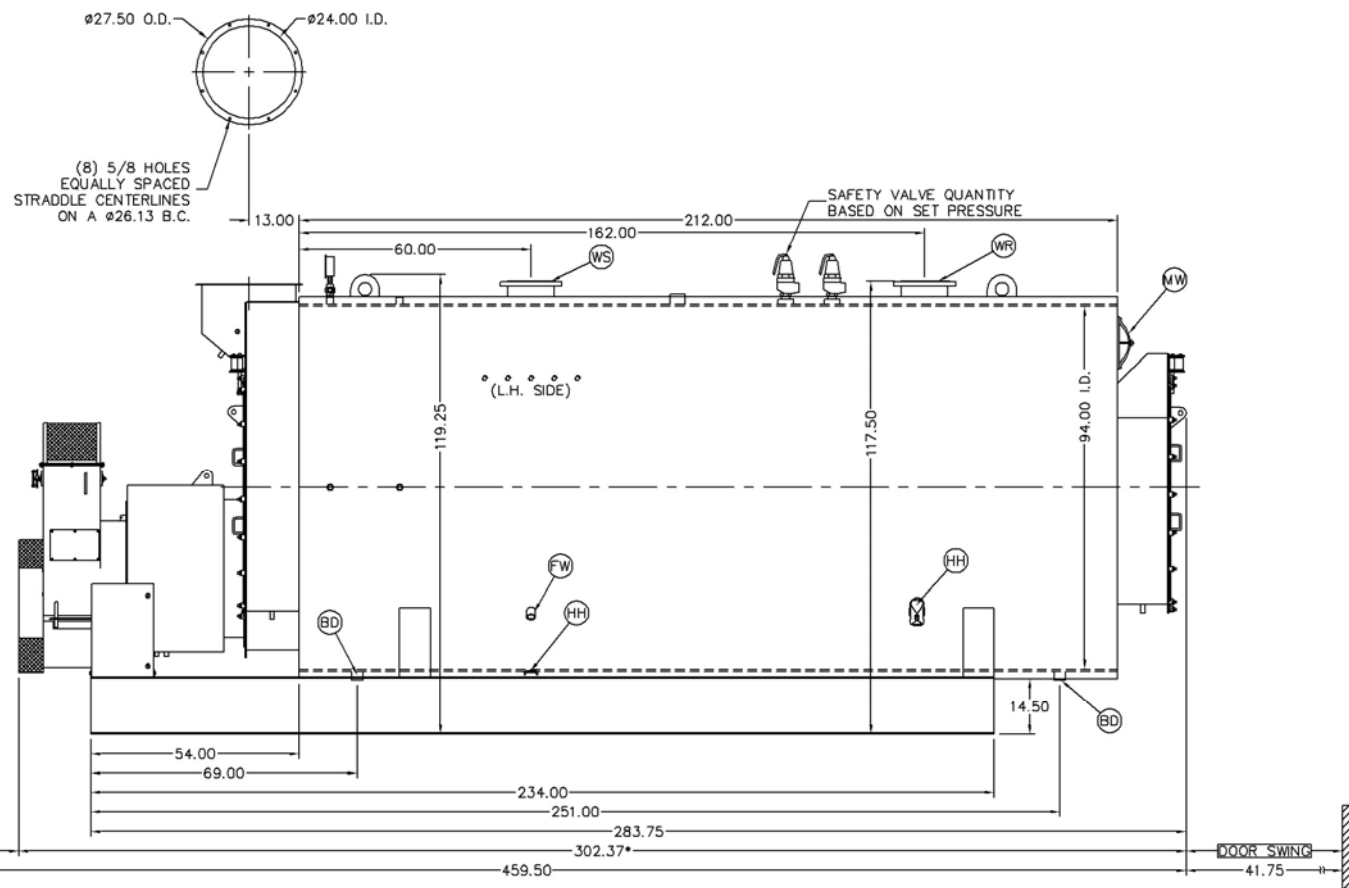
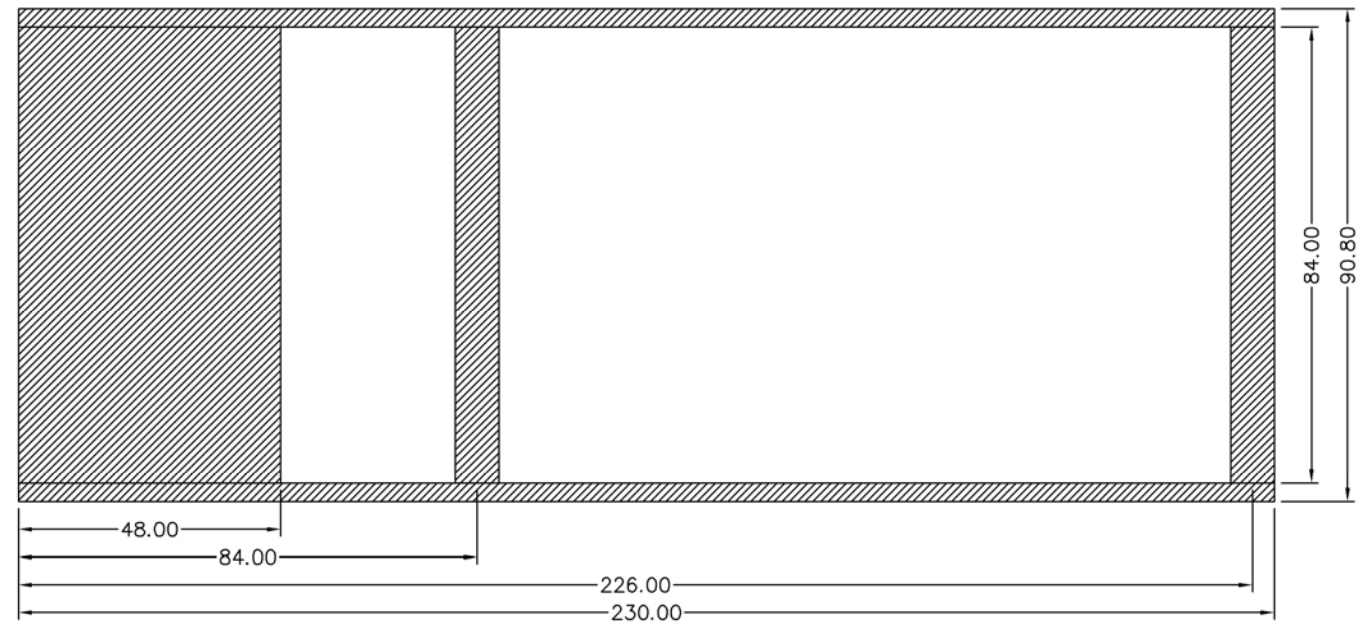

Notes:
 30# Hot Water design shown, all dimensions given in inches.
 Fuel piping and/or optional boiler trim may increase overall width.
 Specifications subject to change to incorporate engineering advances.
 *May vary on low-NO_x designs.

Thermal Expansion				
Metal T _{MAX} (F)	180	200	220	240
L (in)	0.064	0.076	0.089	0.102
WS (in)	0.028	0.033	0.039	0.044
WR (in)	0.034	0.040	0.047	0.054
HT (in)	0.057	0.068	0.079	0.091