

MODEL: PFTA 750-4

Nozzle Loadings

Maximum Allowable Load on Boiler Steam Nozzle					
	15# Design	150# Design	200# Design	250# Design	300# Design
F_{RRF} , lb	6,235	4,695	6,590	8,260	9,810
M_{RCM} , in-lb	50,040	58,795	83,190	109,040	142,075
M_{RLM} , in-lb	79,540	48,155	67,575	90,300	104,430

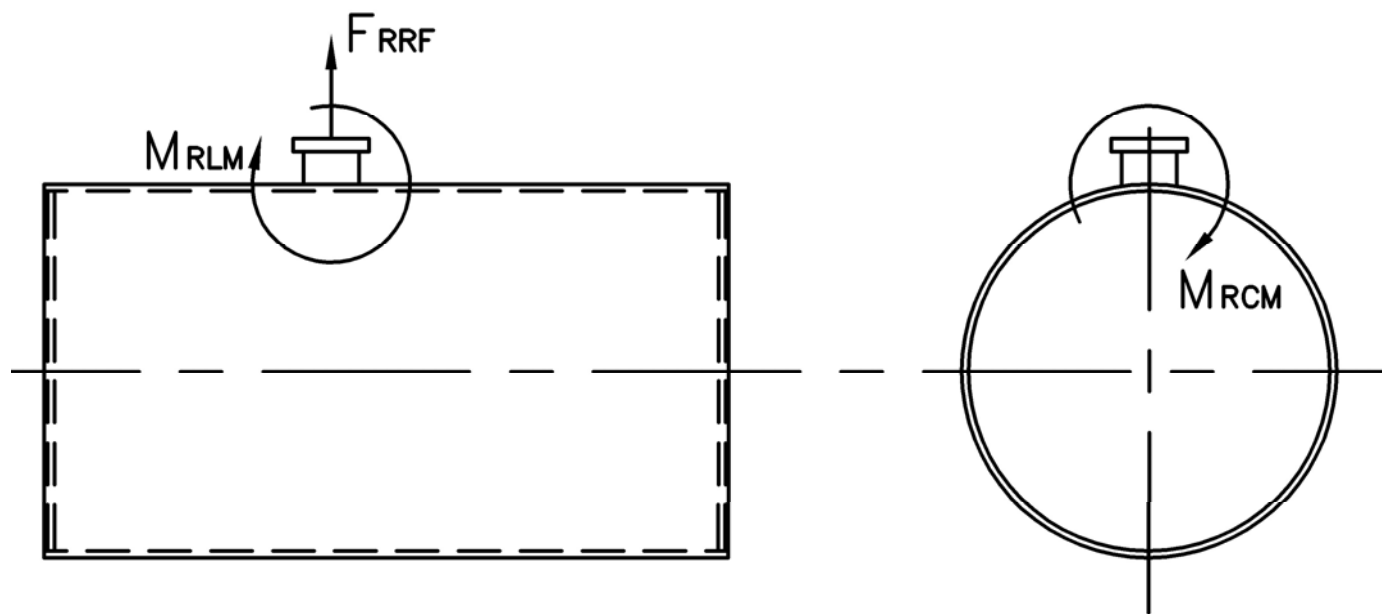

Distributed By:

Stack Emissions-Natural Gas (1,000 Btu/CF)				
	PPMv (Corr to 3% O ₂)	lb/MBtu	lb/hr @ Full Rate	Ton/Yr @ Full Rate
NO _x *	110	0.131	3.963	17.358
	30	0.036	1.081	4.734
	9	0.011	0.324	1.420
CO	50	0.037	1.11	4.870
CO ₂	2.55 lb/lb fuel	119.76	3,624	15,874
H ₂ O	2.03 lb/lb fuel	106.16	3,213	14,072
Stack Emissions-#2 Oil** (140,000 Btu/gal)				
NO _x	128	0.174	5.077	22.239
CO	50	0.037	1.071	4.693
CO ₂	3.20 lb/lb fuel	168.53	4,915	21,527
H ₂ O	1.12 lb/lb fuel	71.20	2,076	9,095

* 110 ppm "A" Burner, 30 ppm A-FGR Burner, 9 ppm FIR Burner
 **0.02% fuel bound Nitrogen



MODEL: PFTA 750-4

4-Pass Steam Packaged Firetube Boiler

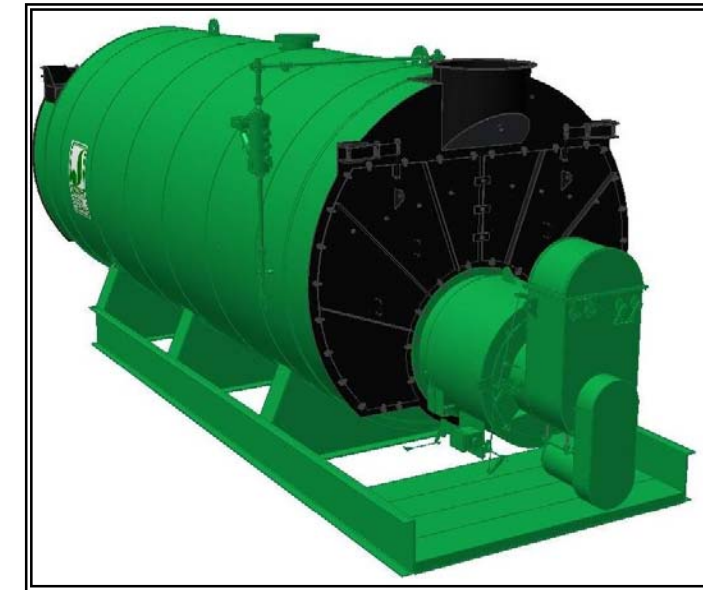

Ratings & Performance Data

Horsepower 750							
Steam Storage, ft ³	148.8	Natural Gas Flow, SCFH (1,000 Btu/ft ³)**	30,263				
Steam Disengaging Area, ft ²	125.1	Combustion Air (15% Excess), SCFM***	5,538				
Total Heating Surface, ft ²	3,727	Flue Gas Flow Rate, lb/hr***	26,391				
Furnace Outside Diameter, in	49.5	Stack Flue Gas Velocity, ft/min***	2,231				
Furnace Heat Release Rate, Btu/ft ³ hr**	161,000	#2 Oil Flow, gal/hr (140,000 BTU/gal)**	208.3				
Total Combustion Volume, ft ³	252.5	#6 Oil Flow, gal/hr (150,000 BTU/gal)**	192.8				
Total Heat Release Rate, Btu/ft ³ hr**	120,000	Flue Gas Side Pressure Drop, in. H ₂ O	6.1				
Water Content N.W.L., gal	4,084	Water Content Flooded, gal.	5,197				
Approx. Dry Weight 15#, lb	51,000	Approx. Operating Weight 15#, lb.	84,200				
Approx. Dry Weight 150#, lb	55,300	Approx. Operating Weight 150#, lb.	88,500				
Approx. Dry Weight 200#, lb	59,300	Approx. Operating Weight 200#, lb.	92,500				
Approx. Dry Weight 250#, lb	63,900	Approx. Operating Weight 250#, lb.	97,100				
Approx. Dry Weight 300#, lb	69,400	Approx. Operating Weight 300#, lb.	102,600				
Performance Data							
Operating Pressure (psig)	Steam Rate (lb/hr)	Natural Gas		#2 Oil		#6 Oil	
		Stack Temp (F)	%Eff	Stack Temp (F)	%Eff	Stack Temp (F)	%Eff
10	26,046	280	85.4	289	88.5	296	89.3
50	25,541	337	84.0	346	87.1	354	87.8
100	25,268	377	83.0	386	86.1	394	86.8
150	25,116	405	82.3	414	85.4	422	86.1
200	25,021	427	81.7	436	84.8	445	85.5
250	24,960	445	81.3	454	84.4	463	85.1
300	24,921	461	80.9	470	84.0	480	84.7

*Based on 228°F feedwater and 3% O₂, ** Values calculated at 100 psi operating pressure, ***Calculated Firing Natural Gas



300 Pine Street
 P.O. Box 300
 Ferrysburg, MI 49409-0300
 Telephone: (616) 842-5050
 Net: www.johnstonboiler.com

Drawings - 4-Pass Steam Packaged Firetube Boiler

MODEL: PFTA 750-4

Connection & Opening Schedule			
Conn.	Description	Type	Qty
FW	Feedwater Inlet	2.00 FNPT	2
MS*	Main Steam	8.00 300# RF	1
CB	Continuous Blowoff	1.00 FNPT	1
BD	Blowdown Outlet	2.00 FNPT	2
MW	Manway	12 X 16	1
HH	Hand Hole	4 X 6	7

*12.00 150#RF Flange on 15 psig Design

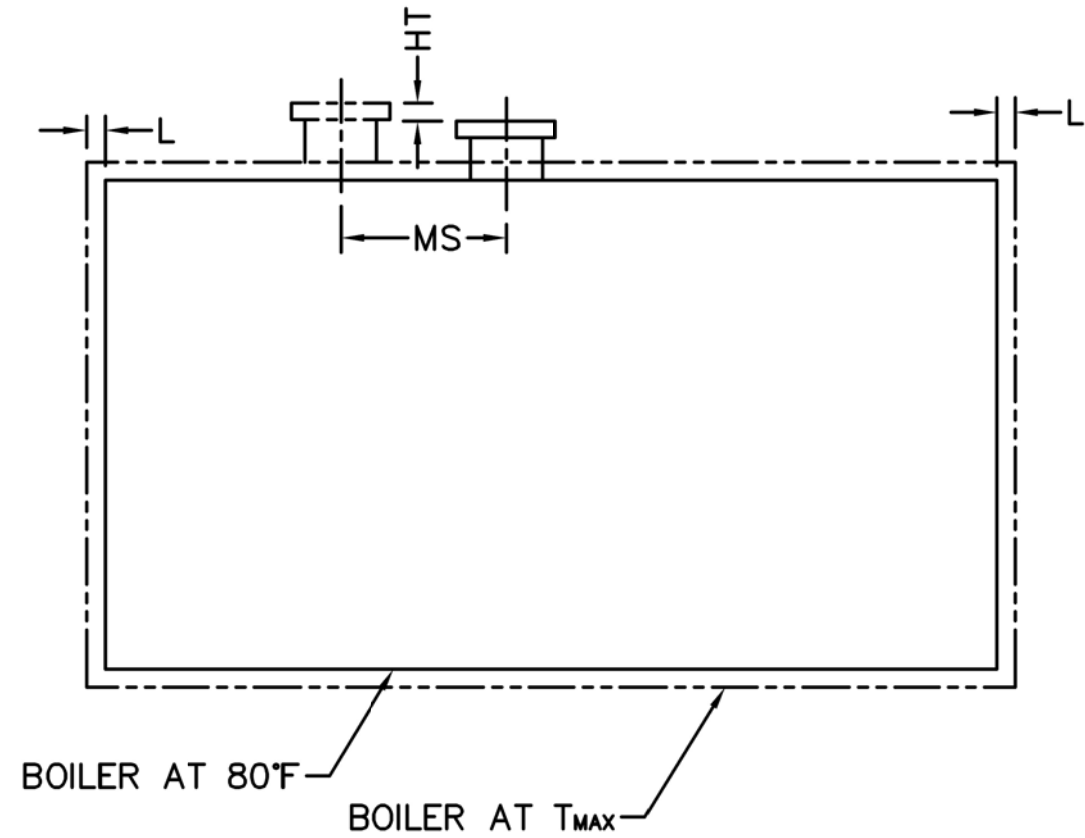
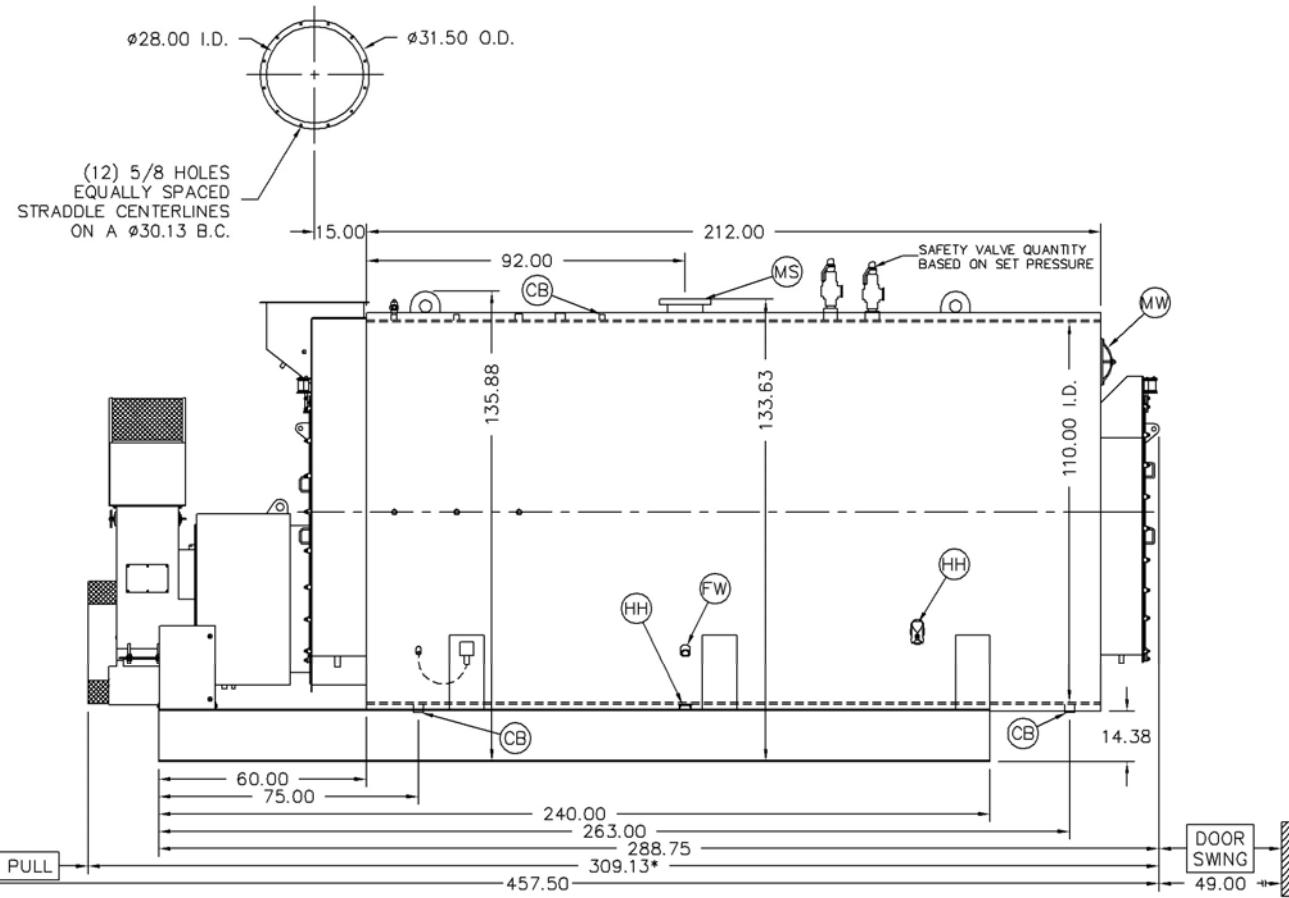
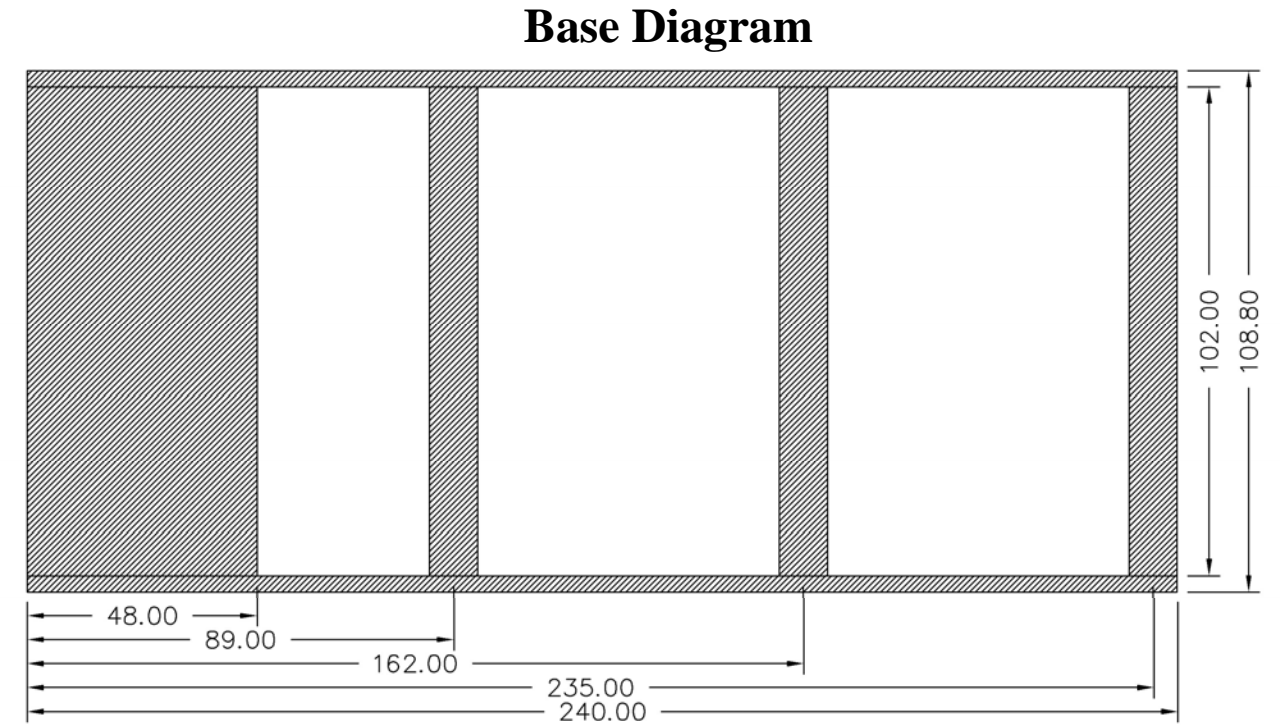
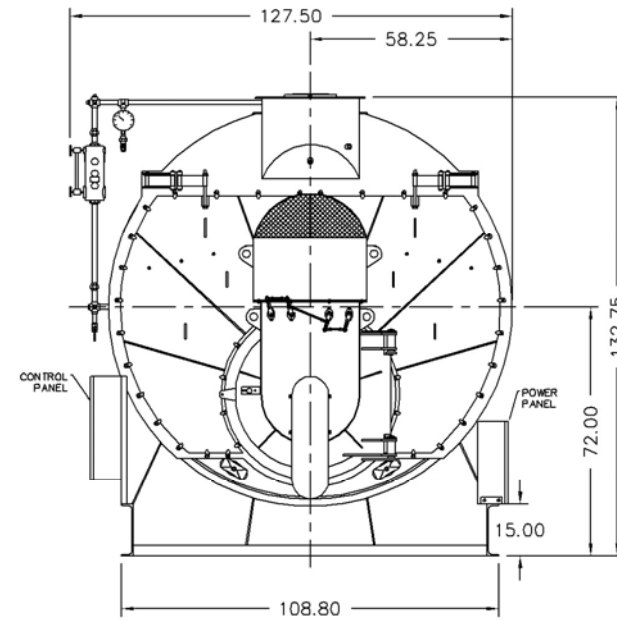

Notes:
 150# Steam design shown, all dimensions given in inches.
 Fuel piping and/or optional boiler trim may increase overall width.
 Specifications subject to change to incorporate engineering advances.
 *May vary on low-NO_x designs

Thermal Expansion					
psig	15	150	200	250	300
Metal T _{MAX} (F)	240	366	388	406	421
L (in)	0.108	0.182	0.196	0.207	0.217
MS (in)	0.014	0.024	0.026	0.027	0.029
HT (in)	0.112	0.190	0.204	0.217	0.228