

# MODEL: PFTX 1200-4

## Nozzle Loadings

Maximum Allowable Load on Outlet & Return Nozzles				
	30# Design	60# Design	125# Design	160# Design
$F_{RRF}$ , lb	6,230	4,590	8,500	9,730
$M_{RCM}$ , in-lb	70,875	70,875	148,900	196,690
$M_{RLM}$ , in-lb	93,515	68,905	138,895	151,400

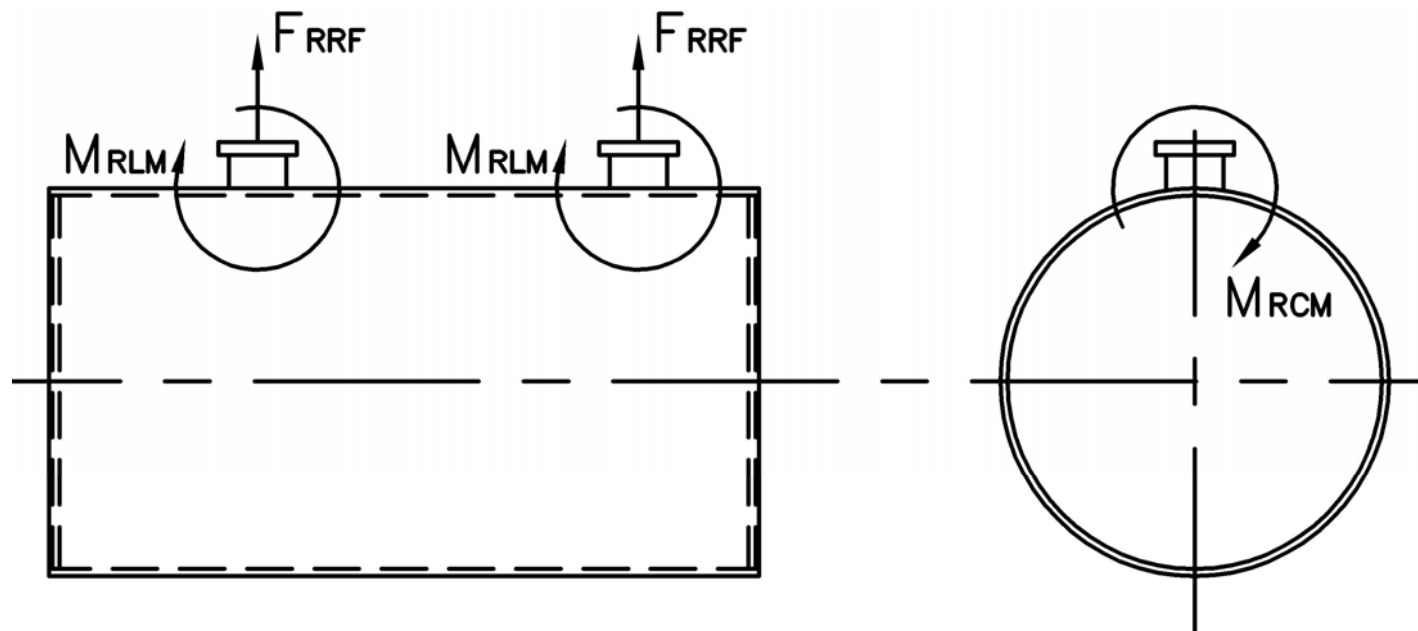

Distributed By:



300 Pine Street  
 P.O. Box 300  
 Ferrysburg, MI 49409-0300  
 Telephone: (616) 842-5050  
 Net: www.johnstonboiler.com

# MODEL: PFTX 1200-4

## 4-Pass Hot Water Packaged Firetube Boiler

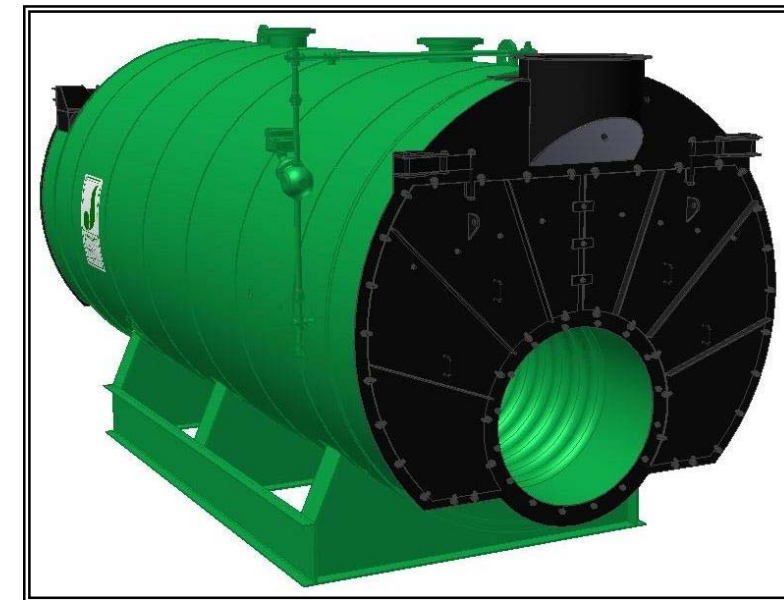

## Ratings & Performance Data

Horsepower 1200		Natural Gas Flow, SCFH (1,000 Btu/ft <sup>3</sup> )**	46,289
Total Heating Surface, ft <sup>2</sup>	6,071	Combustion Air (15% Excess), SCFM***	8,470
Furnace Outside Diameter, in	56.0	Flue Gas Flow Rate, lb/hr***	40,367
Furnace Heat Release Rate, Btu/ft <sup>3</sup> hr**	153,000	Stack Flue Gas Velocity, ft/min***	1,690
Total Combustion Volume, ft <sup>3</sup>	394.5	#2 Oil Flow, gal/hr (140,000 Btu/gal)**	318.8
Total Heat Release Rate, Btu/ft <sup>3</sup> hr**	117,000	#6 Oil Flow, gal/hr (150,000 Btu/gal)**	295.3
Water Content Flooded, gal	8,331	Flue Gas Side Pressure Drop, in. H <sub>2</sub> O	9.6
Approx. Dry Weight 30#, lb	76,700	Approx. Operating Weight 30#, lb	147,100
Approx. Dry Weight 60#, lb	76,900	Approx. Operating Weight 60#, lb	147,300
Approx. Dry Weight 125#, lb	79,100	Approx. Operating Weight 125#, lb	149,500

### Performance Data

Operating Temperature (F)	Natural Gas		#2 Oil		#6 Oil	
	Stack Temp (F)	%Eff	Stack Temp	%Eff	Stack Temp (F)	%Eff
180	205	87.3	211	90.5	218	91.2
200	225	86.8	231	90.0	238	90.7
220	244	86.3	251	89.5	258	90.2
240	264	85.8	271	89.0	279	89.7

\*Based on 20°F difference in supply/return, \*\* Values calculated at 200°F operating temperature, \*\*\*Calculated Firing Natural Gas

Connection & Opening Schedule			
Conn.	Description	Type	Qty
FW	Feedwater Inlet	2.00 FNPT	2
WS	Water Supply	14.00 150#RF	1
WR	Water Return	14.00 150#RF	1
DO	Drain Outlet	2.00 FNPT	2
MW	Manway	12 X 16	1
HH	Hand Hole	4 X 6	7
Supply and return outlets ASME flanged drilling			

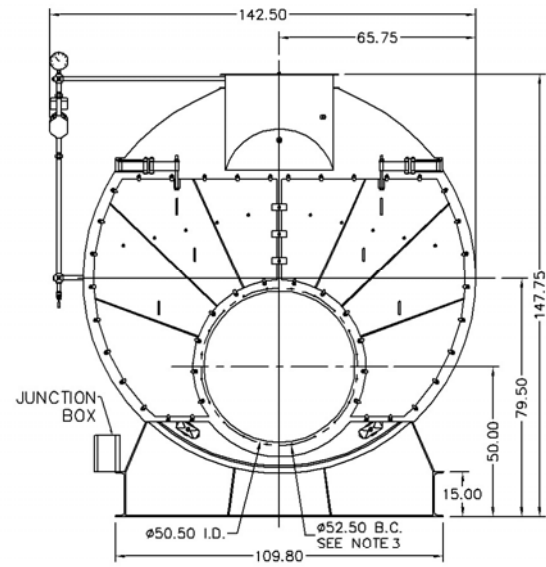

NOTE: (20) 5/8 UNC X 1.500 LONG STUDS EQUALLY SPACED STRADDLE CENTERLINES. STUDS FOR BURNER REFRACTORRY (DRY OVEN) MOUNTING. REFRACTORRY MUST EXTEND 24.00" MINIMUM PAST MOUNTING FLANGE.

Base Diagram

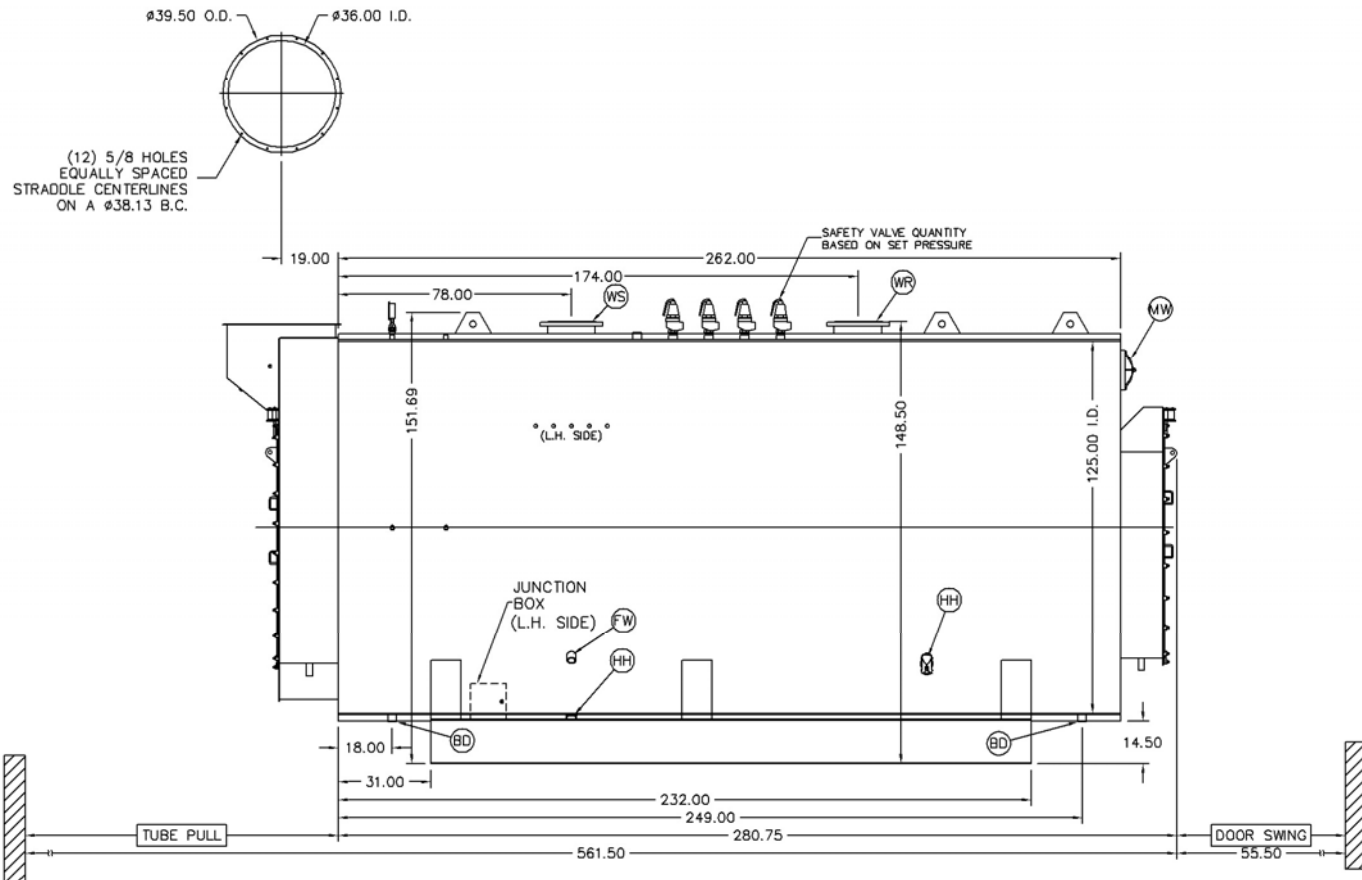
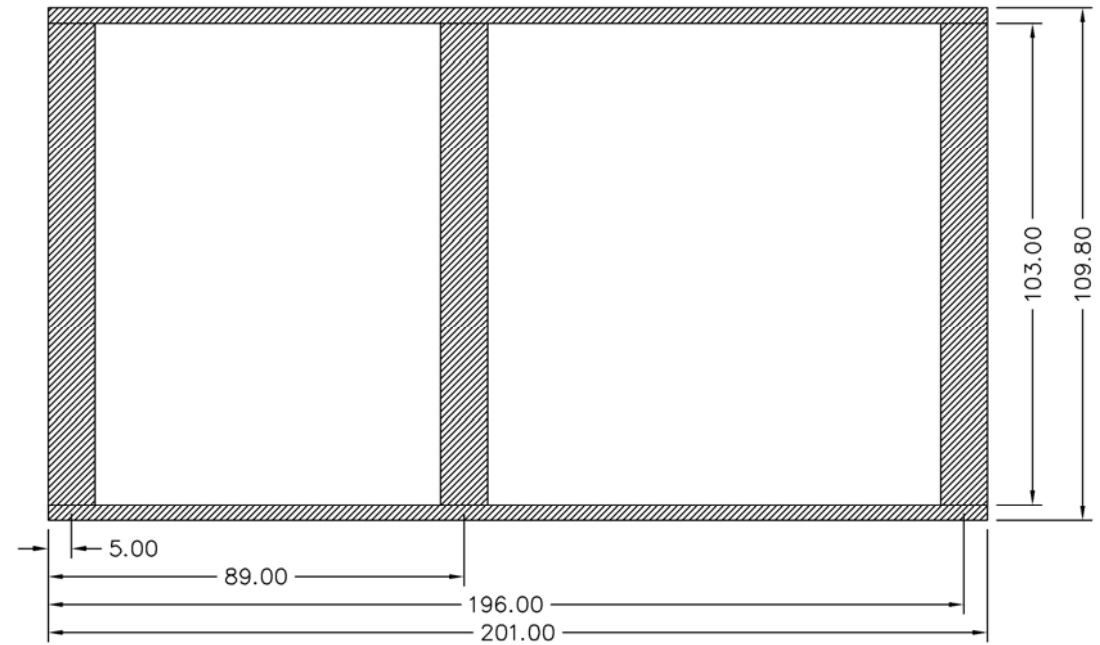

Notes:  
 30# Hot Water design shown, all dimensions given in inches.  
 Fuel piping and/or optional boiler trim may increase overall width.  
 Specifications subject to change to incorporate engineering advances.

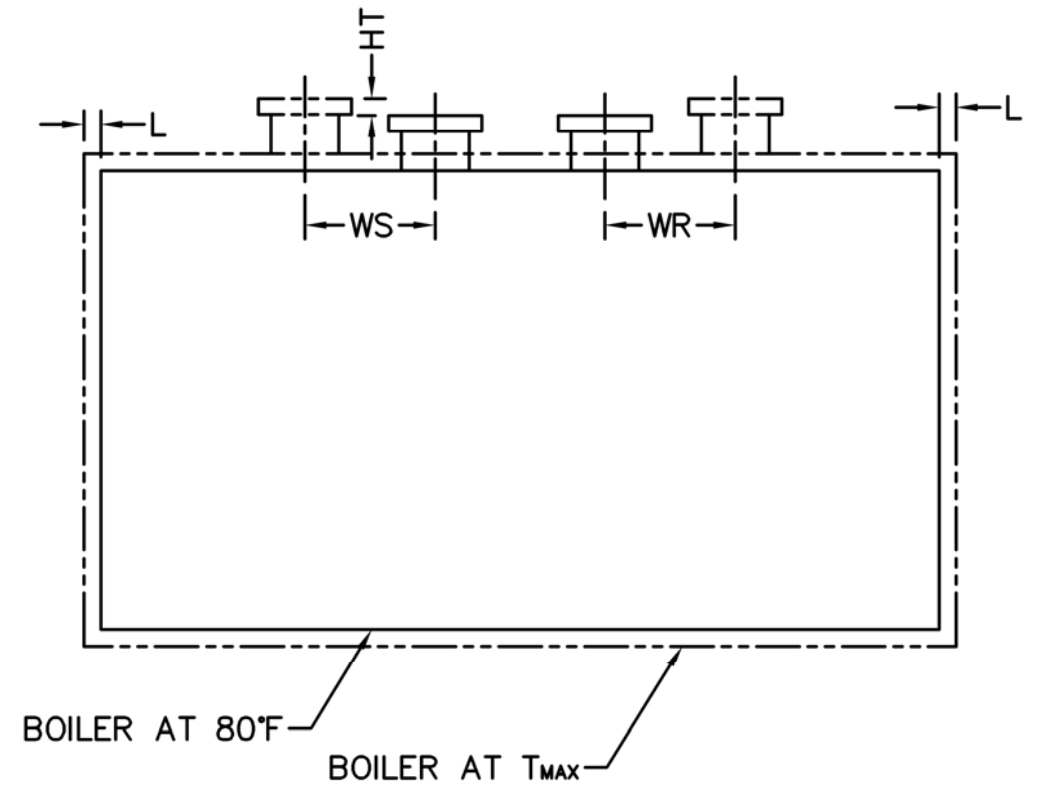

Thermal Expansion				
Metal T <sub>MAX</sub> (F)	180	200	220	240
L (in)	0.079	0.094	0.110	0.126
WS (in)	0.032	0.038	0.045	0.051
WR (in)	0.026	0.031	0.036	0.041
HT (in)	0.075	0.091	0.106	0.121