

MODEL: PFTX 300-4

Nozzle Loadings

Maximum Allowable Load on Boiler Steam Nozzle					
	15# Design	150# Design	200# Design	250# Design	300# Design
F_{RRF} , lb	7,685	3,295	4,420	4,695	5,200
M_{RCM} , in-lb	44,375	31,865	47,345	45,655	51,290
M_{RLM} , in-lb	76,570	23,880	38,175	33,930	36,035

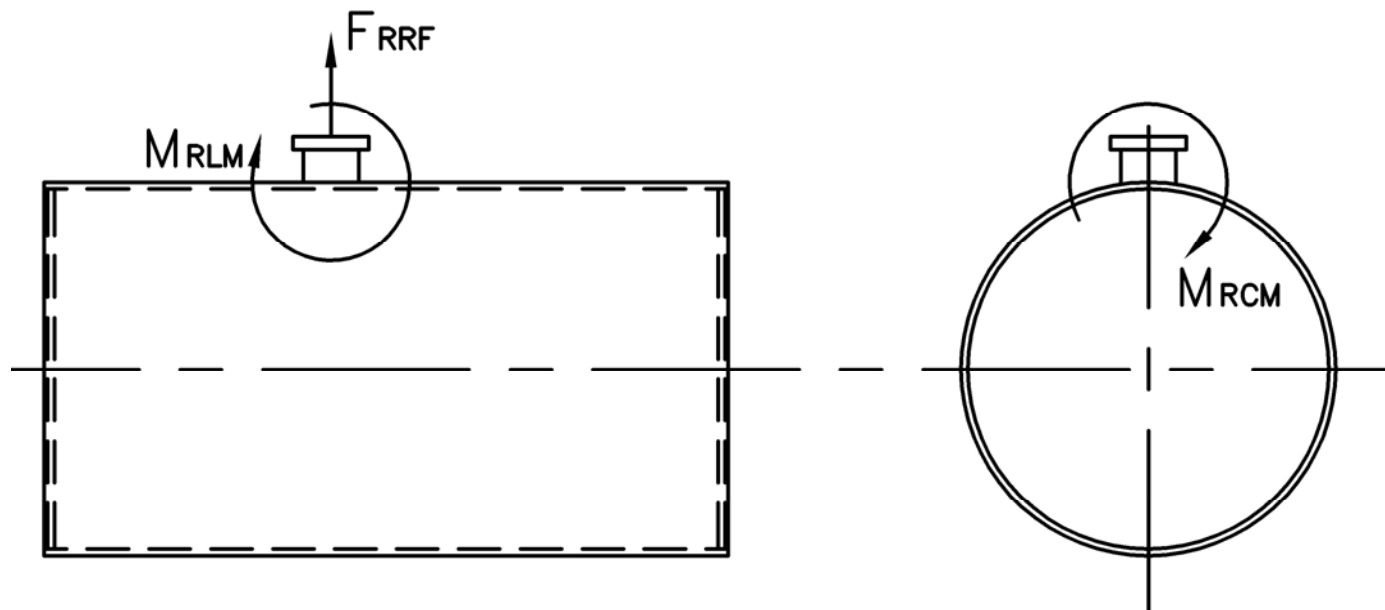

Distributed By:



300 Pine Street
 P.O. Box 300
 Ferrysburg, MI 49409-0300
 Telephone: (616) 842-5050
 Net: www.johnstonboiler.com



MODEL: PFTX 300-4

4-Pass Steam Packaged Firetube Boiler



Ratings & Performance Data

Horsepower 300							
Steam Storage, ft ³	53.4	Natural Gas Flow, SCFH (1,000 Btu/ft ³)**	12,186				
Steam Disengaging Area, ft ²	71.3	Combustion Air (15% Excess), SCFM***	2,230				
Total Heating Surface, ft ²	1,527	Flue Gas Flow Rate, lb/hr***	10,627				
Furnace Outside Diameter, in	38.0	Stack Flue Gas Velocity, ft/min***	2,216				
Furnace Heat Release Rate, Btu/ft ³ hr**	146,000	#2 Oil Flow, gal/hr (140,000 BTU/gal)**	83.9				
Total Combustion Volume, ft ³	120.8	#6 Oil Flow, gal/hr (150,000 BTU/gal)**	77.7				
Total Heat Release Rate, Btu/ft ³ hr**	101,000	Flue Gas Side Pressure Drop, in. H ₂ O	4.0				
Water Content N.W.L., gal	2,054	Water Content Flooded, gal.	2,453				
Approx. Dry Weight 15#, lb	22,600	Approx. Operating Weight 15#, lb.	40,000				
Approx. Dry Weight 150#, lb	25,600	Approx. Operating Weight 150#, lb.	43,000				
Approx. Dry Weight 200#, lb	28,600	Approx. Operating Weight 200#, lb.	46,000				
Approx. Dry Weight 250#, lb	31,400	Approx. Operating Weight 250#, lb.	48,800				
Approx. Dry Weight 300#, lb	34,100	Approx. Operating Weight 300#, lb.	51,500				
Performance Data							
Operating Pressure (psig)	Steam Rate (lb/hr)	Natural Gas		#2 Oil		#6 Oil	
		Stack Temp (F)	%Eff	Stack Temp (F)	%Eff	Stack Temp (F)	%Eff
10	10,418	296	84.9	307	88.0	313	88.7
50	10,216	353	83.4	364	86.5	373	87.2
100	10,107	393	82.4	404	85.5	414	86.2
150	10,046	421	81.7	432	84.8	443	85.4
200	10,008	443	81.1	454	84.2	465	84.9
250	9,984	462	80.7	472	83.7	484	84.4
300	9,968	478	80.2	488	83.3	501	83.9

*Based on 228°F feedwater and 3% O₂, ** Values calculated at 100 psi operating pressure, ***Calculated Firing Natural Gas

Connection & Opening Schedule			
Conn.	Description	Type	Qty
FW	Feedwater Inlet	1.50 FNPT	2
MS*	Main Steam	6.00 300# RF	1
CB	Continuous Blowoff	1.00 FNPT	1
BD	Blowdown Outlet	2.00 FNPT	2
MW	Manway	12 X 16	1
HH	Hand Hole	4 X 6	7

*10.00 150#RF Flange on 15 psig Design

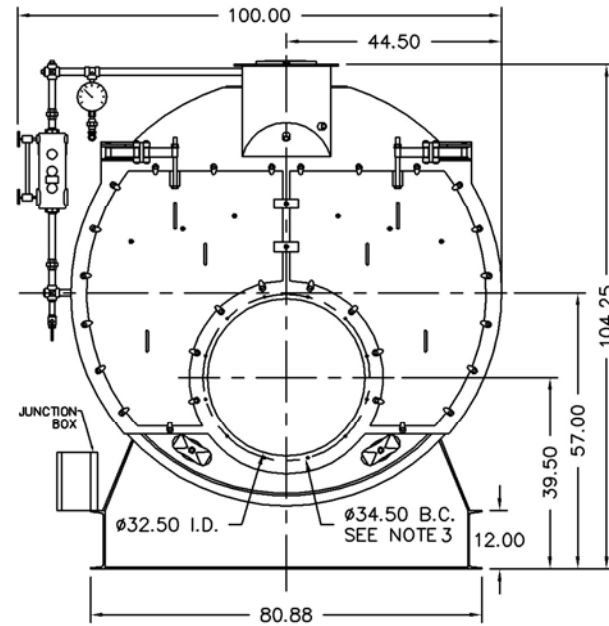

NOTE: (12) 1/2 UNC X 1.375 LONG STUDS EQUALLY SPACED STRADDLE CENTERLINES. STUDS FOR BURNER REFRACTORY (DRY OVEN) MOUNTING. REFRACTORY MUST EXTEND 14.50" MINIMUM PAST MOUNTING FLANGE.

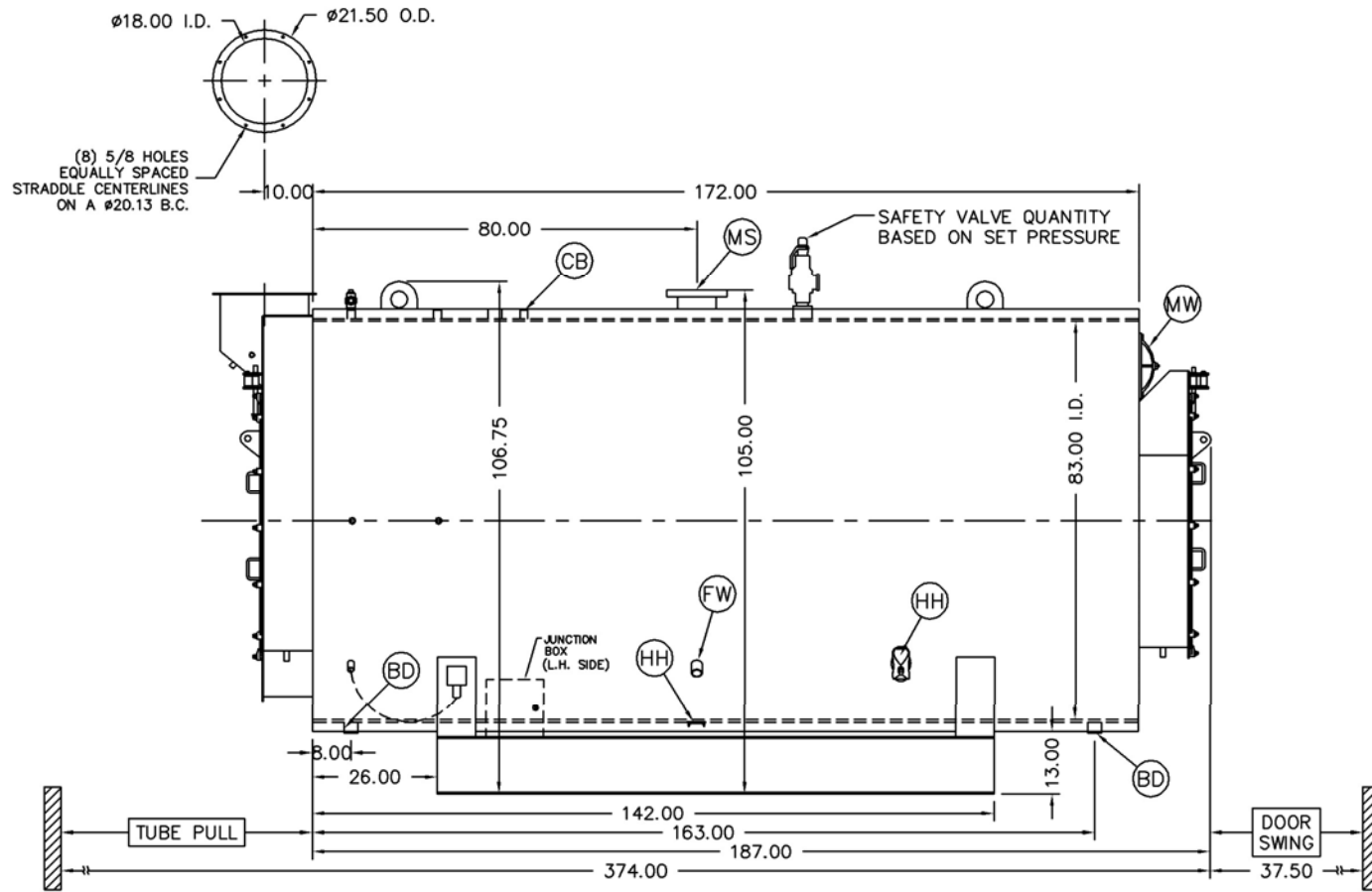

Notes:
 150# Steam design shown, all dimensions given in inches.
 Fuel piping and/or optional boiler trim may increase overall width.
 Specifications subject to change to incorporate engineering advances.

Base Diagram

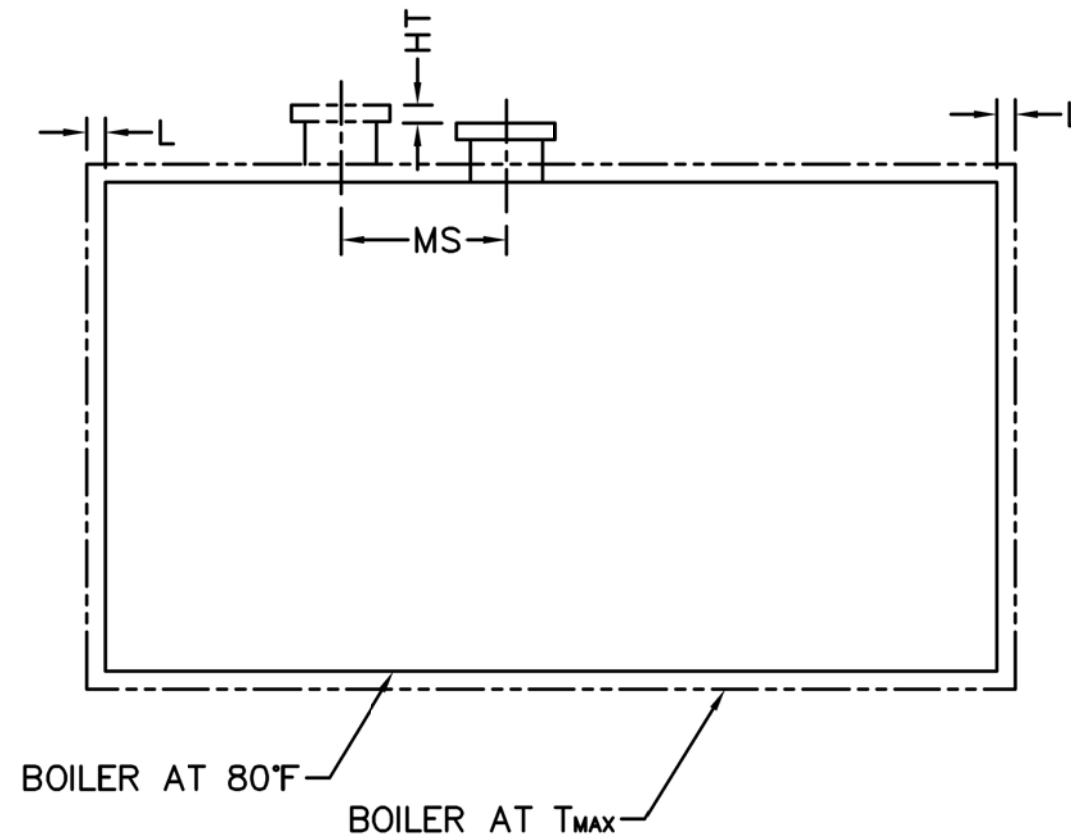
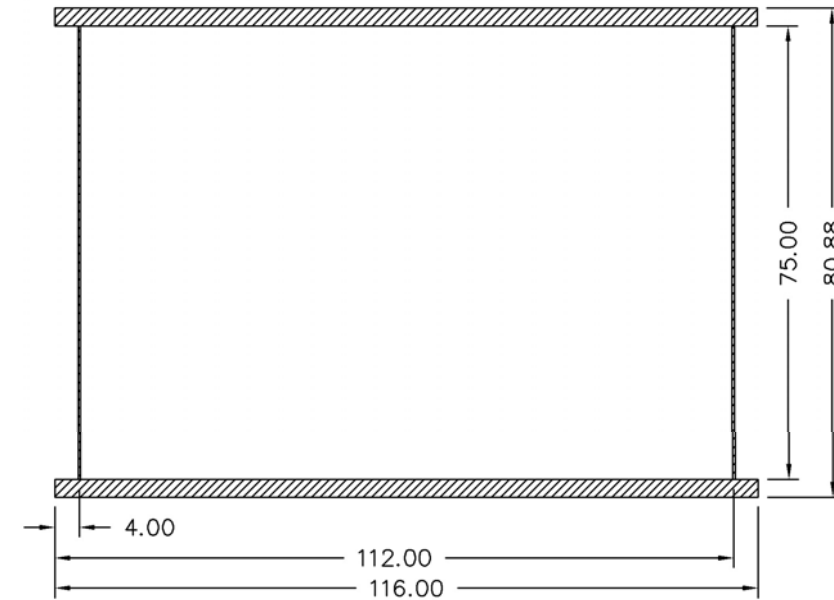

Thermal Expansion					
psig	15	150	200	250	300
Metal T _{MAX} (F)	240	366	388	406	421
L (in)	0.088	0.147	0.159	0.168	0.176
MS (in)	0.006	0.010	0.011	0.012	0.012
HT (in)	0.085	0.143	0.154	0.164	0.172