

MODEL: PFTX 400-4

Nozzle Loadings

Maximum Allowable Load on Boiler Steam Nozzle					
	15# Design	150# Design	200# Design	250# Design	300# Design
F_{RRF} , lb	8,980	2,775	4,335	5,495	4,920
M_{RCM} , in-lb	60,810	28,745	46,625	61,140	56,770
M_{RLM} , in-lb	117,350	24,765	36,950	46,030	47,465

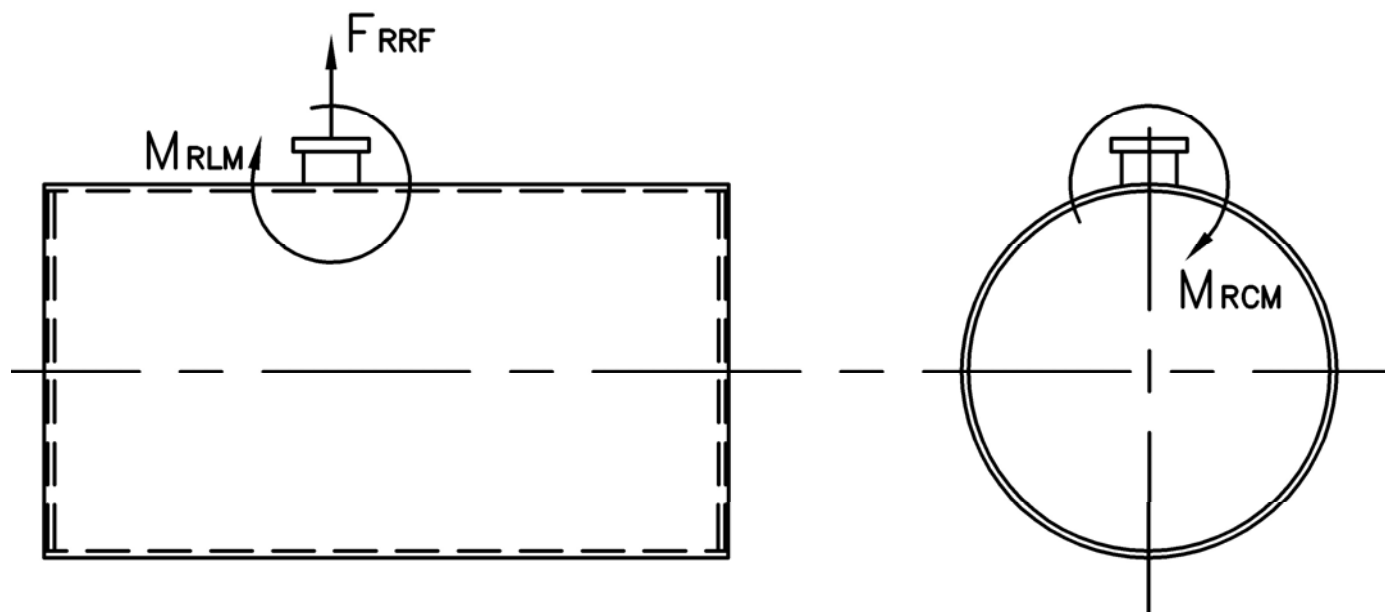

Distributed By:



300 Pine Street
 P.O. Box 300
 Ferrysburg, MI 49409-0300
 Telephone: (616) 842-5050
 Net: www.johnstonboiler.com



MODEL: PFTX 400-4

4-Pass Steam Packaged Firetube Boiler



Ratings & Performance Data

Horsepower 400			
Steam Storage, ft ³	74.8	Natural Gas Flow, SCFH (1,000 Btu/ft ³)**	16,305
Steam Disengaging Area, ft ²	82.2	Combustion Air (15% Excess), SCFM***	2,984
Total Heating Surface, ft ²	2,026	Flue Gas Flow Rate, lb/hr***	14,219
Furnace Outside Diameter, in	42.0	Stack Flue Gas Velocity, ft/min***	2,017
Furnace Heat Release Rate, Btu/ft ³ hr**	161,000	#2 Oil Flow, gal/hr (140,000 BTU/gal)**	112.3
Total Combustion Volume, ft ³	148.0	#6 Oil Flow, gal/hr (150,000 BTU/gal)**	104.2
Total Heat Release Rate, Btu/ft ³ hr**	110,000	Flue Gas Side Pressure Drop, in. H ₂ O	3.9
Water Content N.W.L., gal	2,435	Water Content Flooded, gal.	2,995
Approx. Dry Weight 15#, lb	27,400	Approx. Operating Weight 15#, lb.	48,000
Approx. Dry Weight 150#, lb	31,400	Approx. Operating Weight 150#, lb.	52,000
Approx. Dry Weight 200#, lb	35,100	Approx. Operating Weight 200#, lb.	55,700
Approx. Dry Weight 250#, lb	39,600	Approx. Operating Weight 250#, lb.	60,200
Approx. Dry Weight 300#, lb	44,200	Approx. Operating Weight 300#, lb.	64,800

Performance Data							
Operating Pressure (psig)	Steam Rate (lb/hr)	Natural Gas		#2 Oil		#6 Oil	
		Stack Temp (F)	%Eff	Stack Temp (F)	%Eff	Stack Temp (F)	%Eff
10	13,891	308	84.6	320	87.7	335	88.2
50	13,622	366	83.2	379	86.2	394	86.7
100	13,476	407	82.1	419	85.2	436	85.7
150	13,395	435	81.4	448	84.4	466	84.9
200	13,344	458	80.8	470	83.8	489	84.3
250	13,312	476	80.4	489	83.4	508	83.8
300	13,291	492	79.9	505	82.9	525	83.4

*Based on 228°F feedwater and 3% O₂, ** Values calculated at 100 psi operating pressure, *** Calculated Firing Natural Gas

Connection & Opening Schedule			
Conn.	Description	Type	Qty
FW	Feedwater Inlet	2.00 FNPT	2
MS*	Main Steam	6.00 300# RF	1
CB	Continuous Blowoff	1.00 FNPT	1
BD	Blowdown Outlet	2.00 FNPT	2
MW	Manway	12 X 16	1
HH	Hand Hole	4 X 6	7
*10.00 150#RF Flange on 15 psig Design			

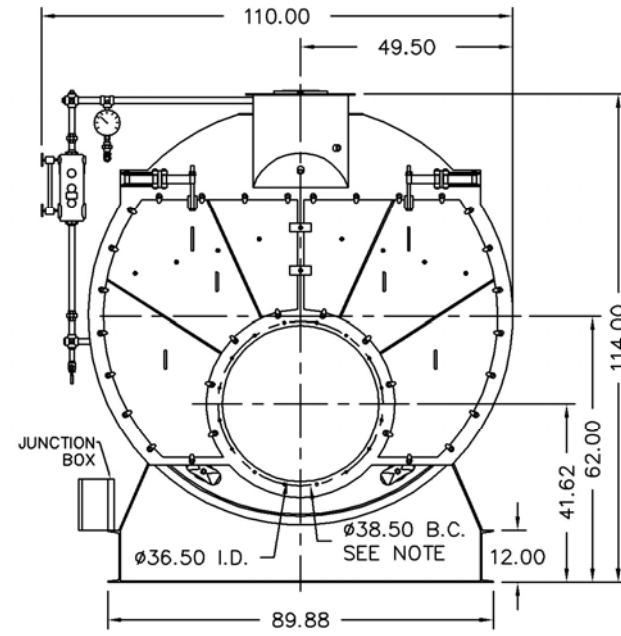

NOTE: (16) 1/2 UNC X 1.50 LONG STUDS EQUALLY SPACED STRADDLE CENTERLINES. STUDS FOR BURNER REFRACTORY (DRY OVEN) MOUNTING. REFRACTORY MUST EXTEND 17.25" MINIMUM PAST MOUNTING FLANGE.

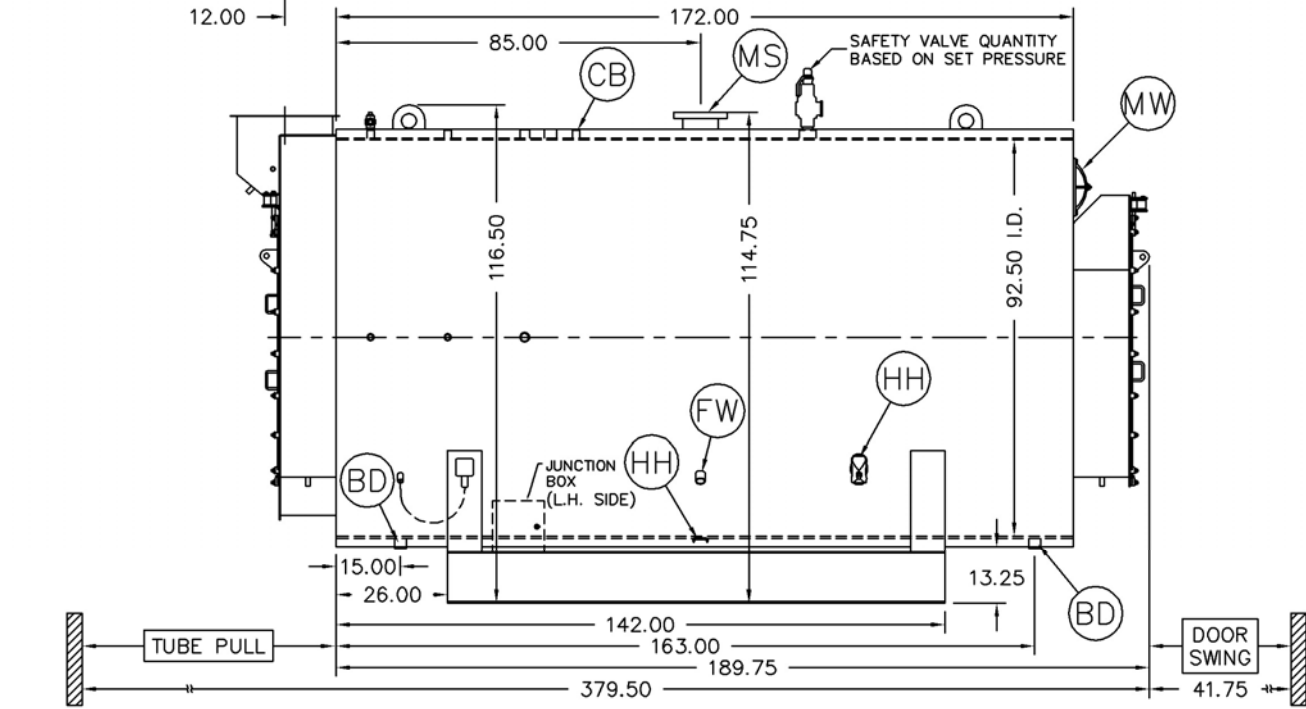
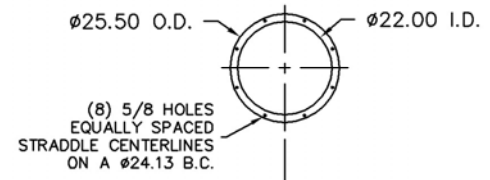

Notes:
 150# Steam design shown, all dimensions given in inches.
 Fuel piping and/or optional boiler trim may increase overall width.
 Specifications subject to change to incorporate engineering advances.

Base Diagram

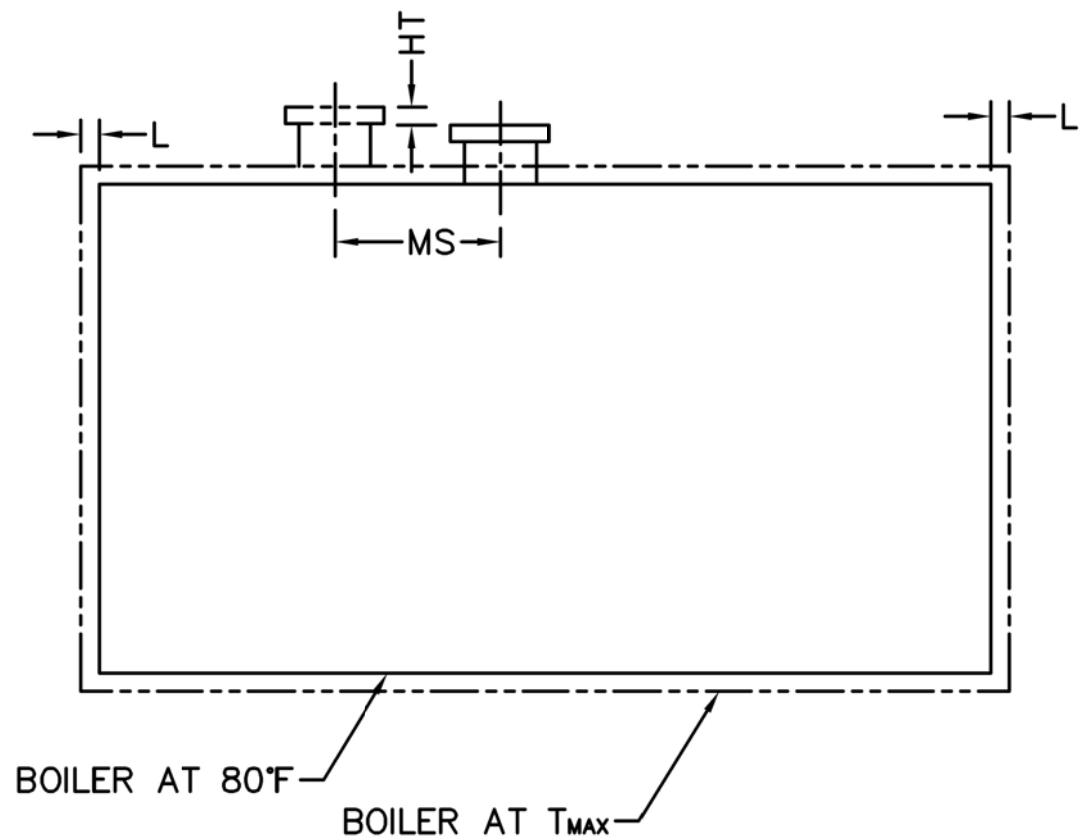
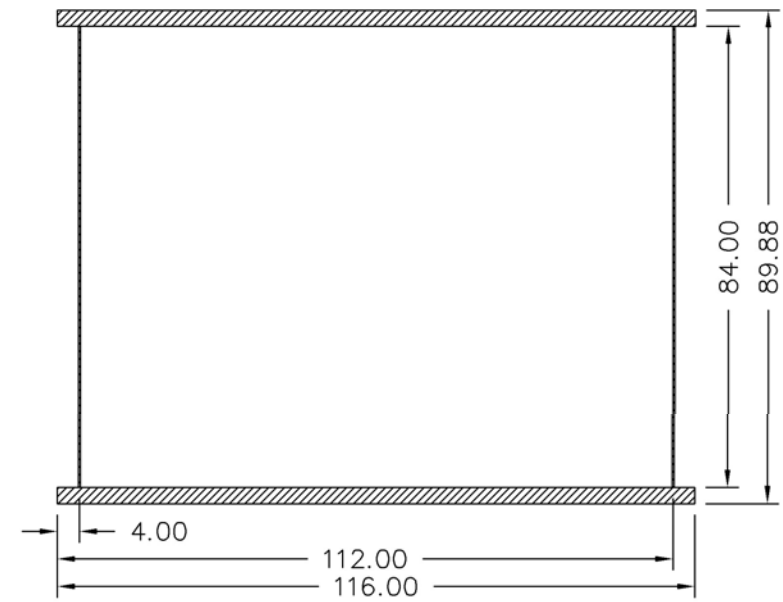

Thermal Expansion					
psig	15	150	200	250	300
Metal T _{MAX} (F)	240	366	388	406	421
L (in)	0.088	0.147	0.159	0.168	0.176
MS (in)	0.001	0.002	0.002	0.002	0.002
HT (in)	0.095	0.160	0.172	0.182	0.191