

NOTES:

1. MINIMUM AISLE CLEARANCE 36" FROM BOILER SIDES AND REAR. (THIS REQUIREMENT MAY VARY WITH LOCATION. CHECK STATE AND LOCAL CODES IN THE AREA OF INSTALLATION.)
2. OPTIONS AND ADDITIONAL EQUIPMENT ORDERED MAY AFFECT OVERALL DIMENSIONS. DRAWINGS ARE FOR STANDARD BOILER PACKAGE.
3. (16) 5/8 UNC X 1.500 LONG STUDS EQUALLY SPACED STRADDLE CENTERLINES. STUDS FOR BURNER REFRACTORY (DRY OVEN) MOUNTING. REFRACTORY MUST EXTEND 18.75" MINIMUM PAST MOUNTING FLANGE.

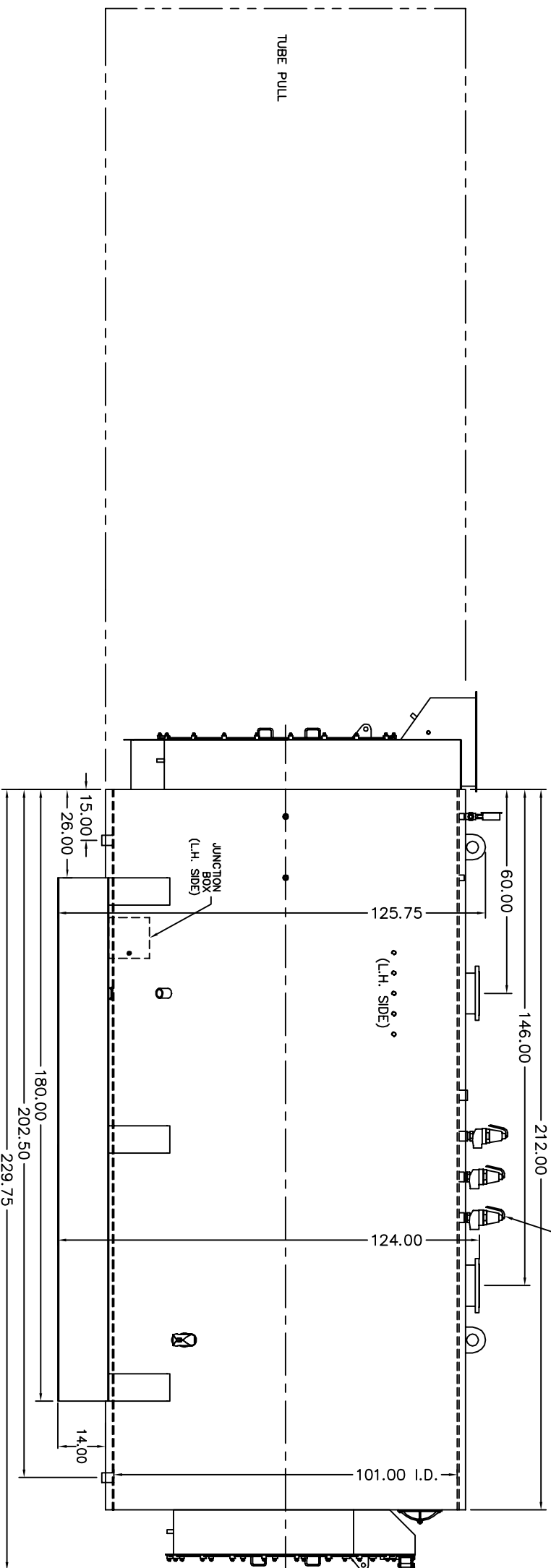
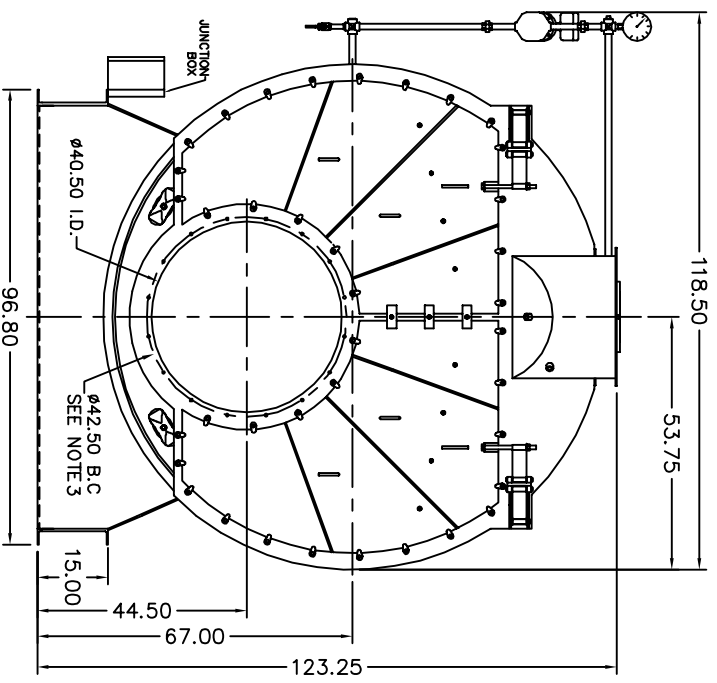
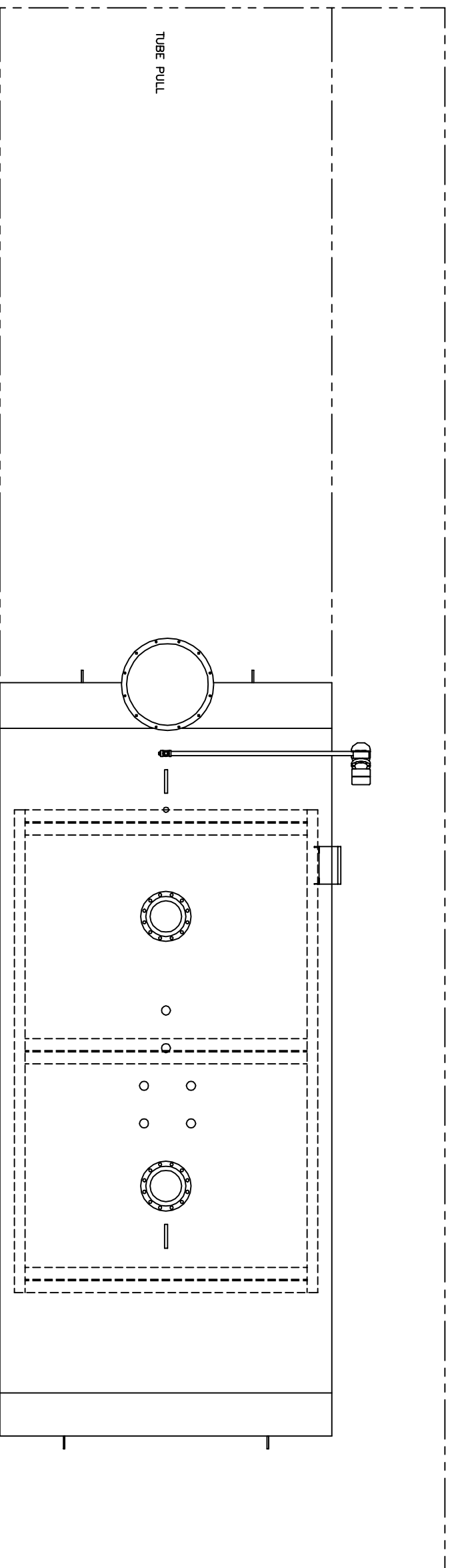

DWG NO. 300B0459

REVISIONS

NO.	DESCRIPTION

REFERENCE DRAWINGS

PLENUM: #212B0150
 PV BASE: #101B0941
 RR FLUE BOX: #205B0148
 RR FLUE BOX: #206B0138

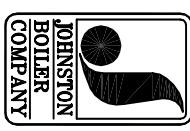

THIS DRAWING IS THE PROPERTY OF THE JOHNSTON BOILER COMPANY. THE DISCLOSURES CONTAINED ON THIS DRAWING ARE MADE WITH THE UNDERSTANDING THAT THEY ARE CONFIDENTIAL AND WILL NOT BE USED IN ANY WAY DETRIMENTAL TO THIS COMPANY'S INTEREST.

SCALE	CAD/FULL
DATE	2-26-07
DRAWN	JRS
CHECKED	
APPROVED	

JOHNSTON BOILER COMPANY
 FERRYSBURG, MICHIGAN 49409

BOILER TEMPLATE - 509
 PFTX600-4-30#W

DWG. NO. 300B0459-03

SO#	
REV	