

MODEL: PFTX 900-4

Nozzle Loadings

Maximum Allowable Load on Outlet & Return Nozzles				
	30# Design	60# Design	125# Design	160# Design
F_{RRF} , lb	4,850	3,700	4,790	7,595
M_{RCM} , in-lb	40,330	40,330	64,670	115,985
M_{RLM} , in-lb	52,165	39,795	51,500	86,200

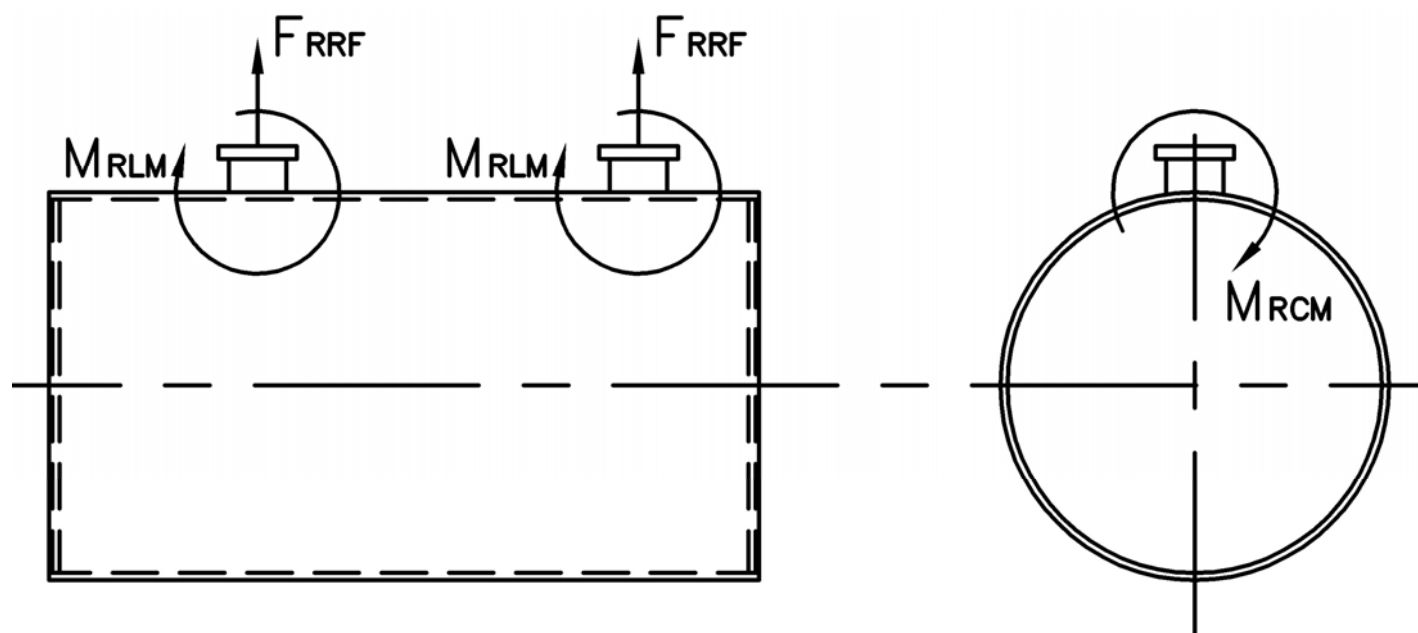

Distributed By:



300 Pine Street
P.O. Box 300
Ferrysburg, MI 49409-0300
Telephone: (616) 842-5050
Net: www.johnstonboiler.com

MODEL: PFTX 900-4

4-Pass Hot Water Packaged Firetube Boiler

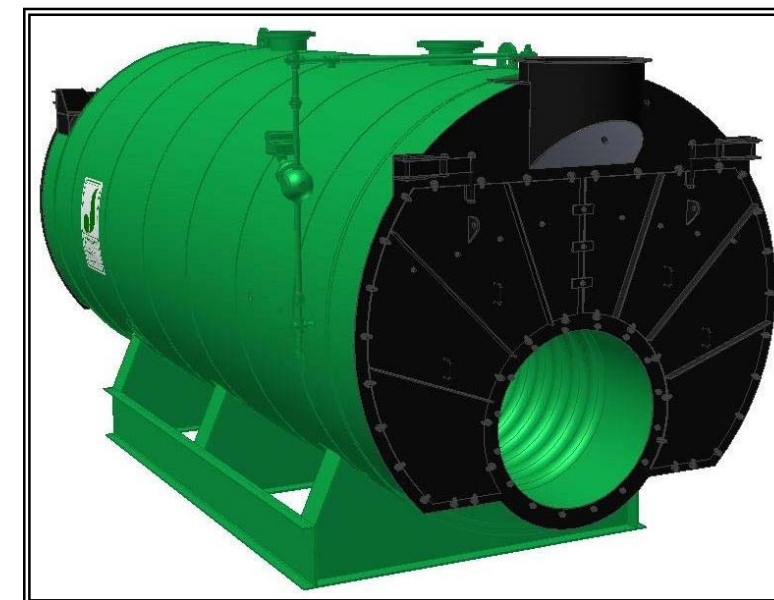

Ratings & Performance Data

Horsepower 900		Natural Gas Flow, SCFH (1,000 Btu/ft ³)**	34,785
Total Heating Surface, ft ²	4,556	Combustion Air (15% Excess), SCFM***	6,365
Furnace Outside Diameter, in	52.0	Flue Gas Flow Rate, lb/hr***	30,335
Furnace Heat Release Rate, Btu/ft ³ hr**	149,000	Stack Flue Gas Velocity, ft/min***	1,619
Total Combustion Volume, ft ³	312.5	#2 Oil Flow, gal/hr (140,000 Btu/gal)**	239.6
Total Heat Release Rate, Btu/ft ³ hr**	111,000	#6 Oil Flow, gal/hr (150,000 Btu/gal)**	221.8
Water Content Flooded, gal	6,309	Flue Gas Side Pressure Drop, in. H ₂ O	7.6
Approx. Dry Weight 30#, lb	58,400	Approx. Operating Weight 30#, lb	111,400
Approx. Dry Weight 60#, lb	58,600	Approx. Operating Weight 60#, lb	111,600
Approx. Dry Weight 125#, lb	61,100	Approx. Operating Weight 125#, lb	114,100

Operating Temperature (F)	Natural Gas		#2 Oil		#6 Oil	
	Stack Temp (F)	%Eff	Stack Temp	%Eff	Stack Temp (F)	%Eff
180	211	87.1	218	90.3	224	91.0
200	230	86.6	238	89.8	243	90.6
220	250	86.1	257	89.3	263	90.1
240	270	85.6	277	88.8	283	89.6

*Based on 20°F difference in supply/return, ** Values calculated at 200°F operating temperature, ***Calculated Firing Natural Gas

Connection & Opening Schedule			
Conn.	Description	Type	Qty
FW	Feedwater Inlet	2.00 FNPT	2
WS	Water Supply	12.00 150#RF	1
WR	Water Return	12.00 150#RF	1
DO	Drain Outlet	2.00 FNPT	2
MW	Manway	12 X 16	1
HH	Hand Hole	4 X 6	7
Supply and return outlets ASME flanged drilling			

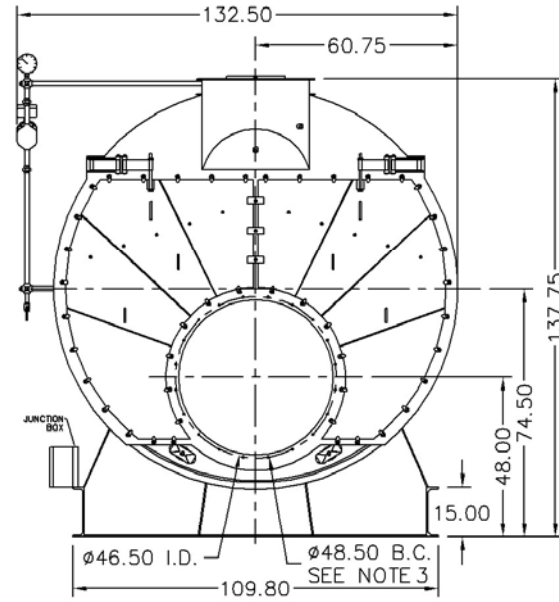

NOTE: (20) 5/8 UNC X 1.500 LONG STUDS EQUALLY SPACED STRADDLE CENTERLINES. STUDS FOR BURNER REFRACTORY (DRY OVEN) MOUNTING. REFRACTORY MUST EXTEND 22.25" MINIMUM PAST MOUNTING FLANGE.

Base Diagram

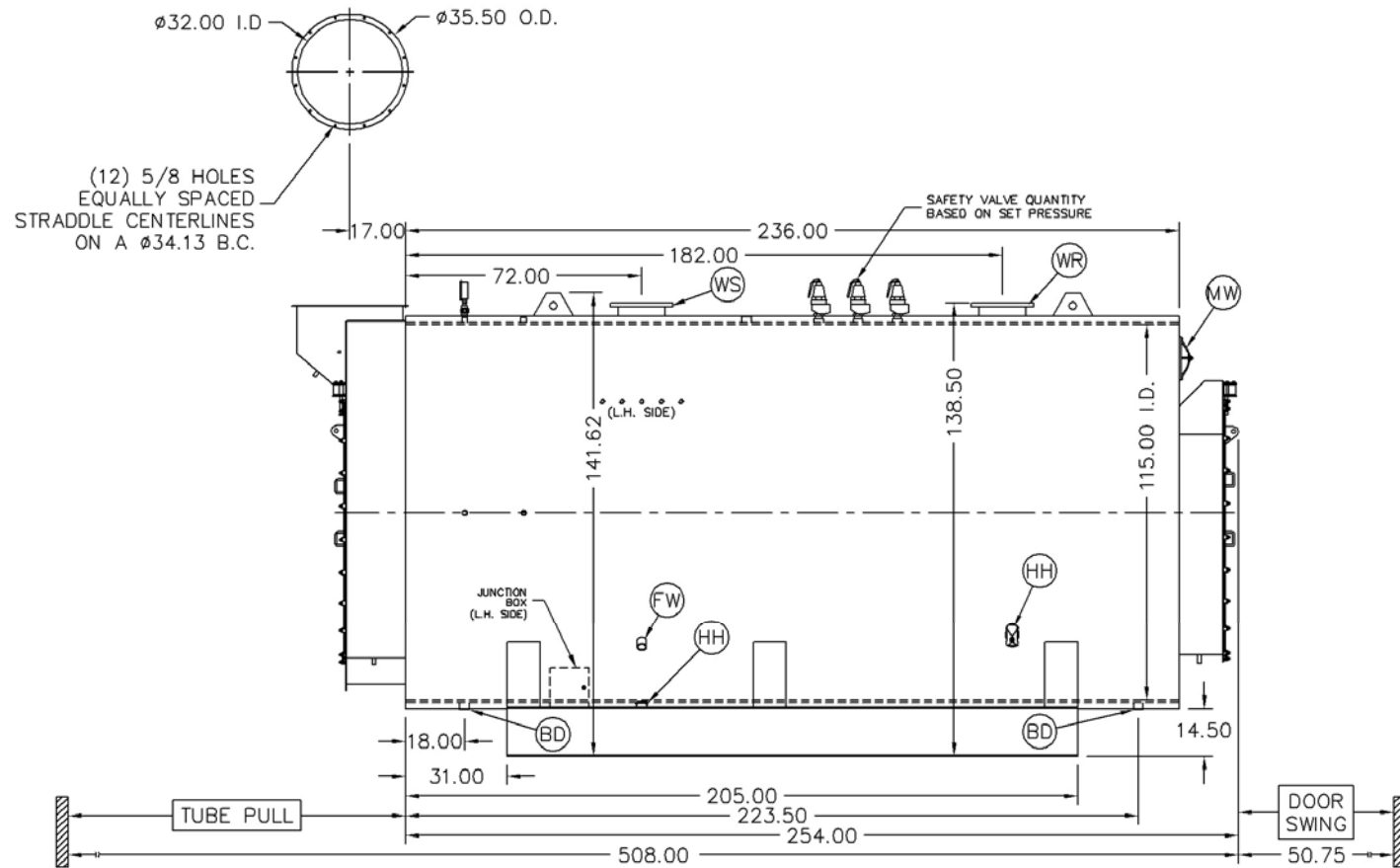
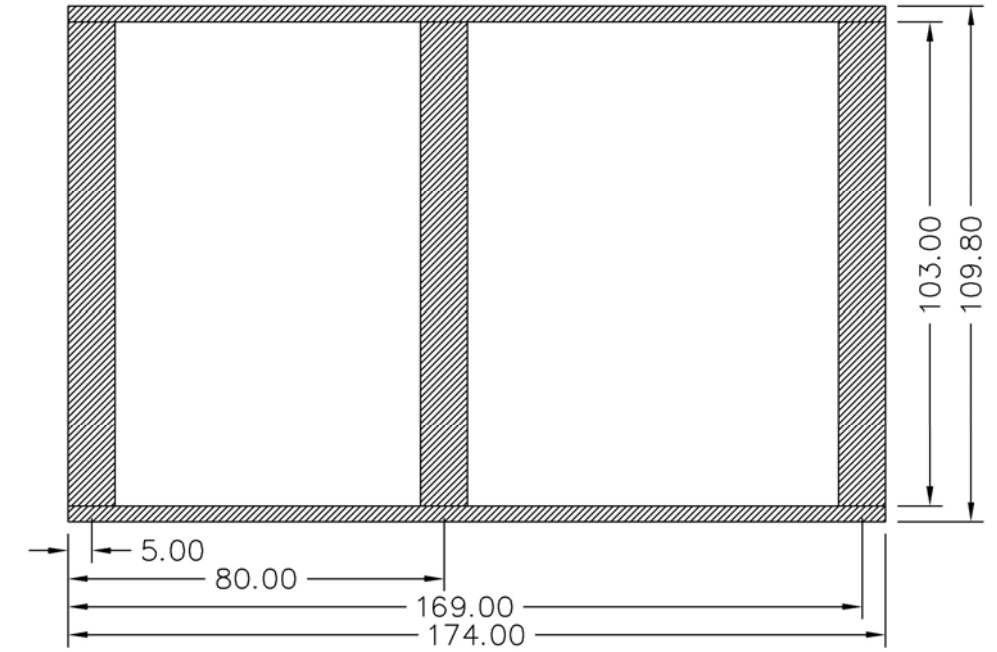

Notes:
 30# Hot Water design shown, all dimensions given in inches.
 Fuel piping and/or optional boiler trim may increase overall width.
 Specifications subject to change to incorporate engineering advances.

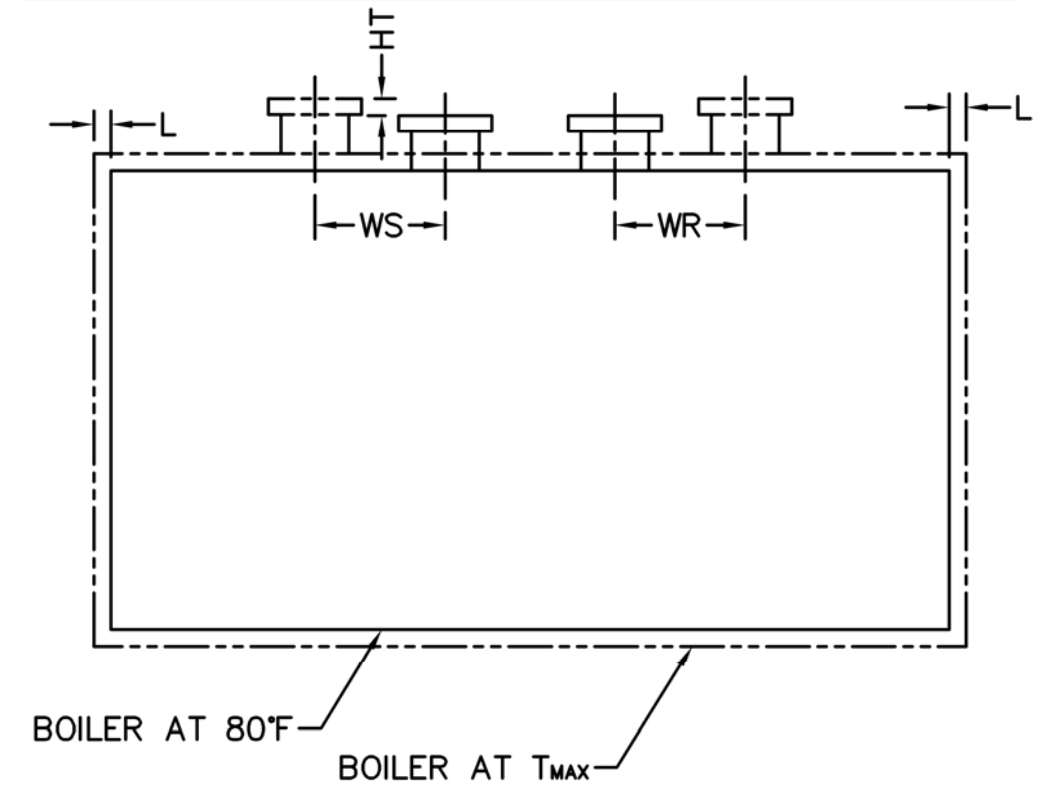

Thermal Expansion				
Metal T _{MAX} (F)	180	200	220	240
L (in)	0.071	0.085	0.099	0.113
WS (in)	0.027	0.033	0.038	0.044
WR (in)	0.039	0.046	0.054	0.062
HT (in)	0.069	0.083	0.097	0.111